

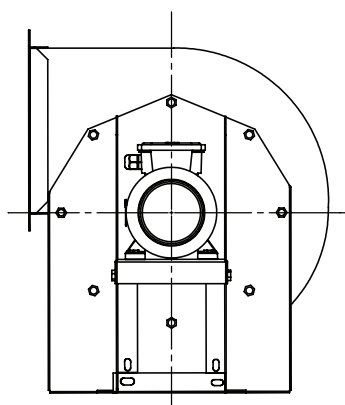

**RADIAL FANS**

## RADIAL FAN DIRECTIONS



L180

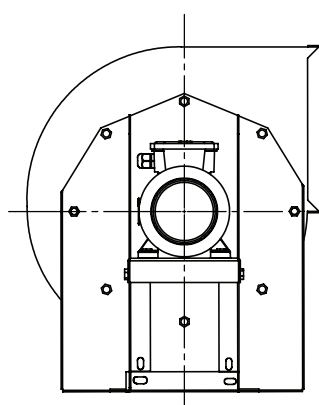

R180

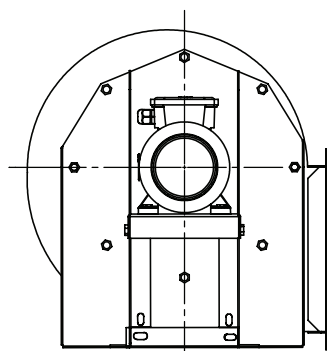

L270

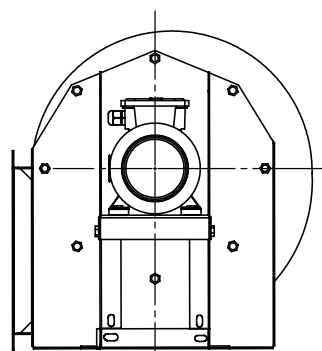

R270

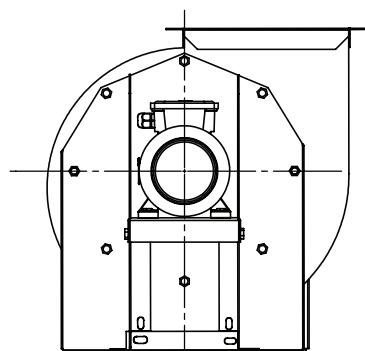

L090

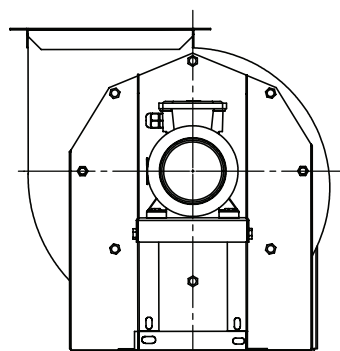

R090



# RFAB

## SINGLE SUCTION INDUSTRIAL RADIAL FANS (FORWARD CURVED) LOW PRESSURE

**RFAB** for low pressure systems. These fans designed for all kind in plant ventilation they can be used. Screw mounting. Thanks to the system, the desired safe comfortably into the shooting position they can be translated. The most economical from ventilation solutions is one.

### MATERIAL

The assembly is electrostatic powder coated DKP. It is made of black sheet. Radial fan, forward DKP black with curved dense propeller structure. Made of sheet metal.

### SPEED CONTROL

Optionally with frequency inverter they can be provided.

### USAGE AREAS

Various heating-ventilation and low running where vibration is undesirable electronics and the like using speeds. It is used for the cooling of equipment. Convenience in manufacturing and assembly upon request. Manufacture of square-bodied fan that provides available.

Type/Code	Electrical Motor				Max. Air Flow	Max. Pressure
	Voltage	Power		Speed		
	(V)	(HP)	(kW)	(d/d) (rpm)	m <sup>3</sup> / h	Pa
RFAB-0,50-T-4K	380	0,50	0,37	1.380	2.000	400
RFAB-1,00-T-4K	380	1,00	0,75	1.410	3.000	500
RFAB-1,50-T-4K	380	1,50	1,10	1.430	4.000	600
RFAB-2,00-T-4K	380	2,00	1,50	1.430	5.000	700
RFAB-3,00-T-4K	380	3,00	2,20	1.435	6.500	800
RFAB-4,00-T-4K	380	4,00	3,00	1.435	7.500	900
RFAB-5,50-T-4K	380	5,50	4,00	1.455	8.500	1.000
RFAB-7,50-T-4K	380	7,50	5,50	1.465	10.500	1.100
RFAB-10,0-T-4K	380	10,0	7,50	1.465	12.500	1.200



**TECHNICAL DIMENSION**

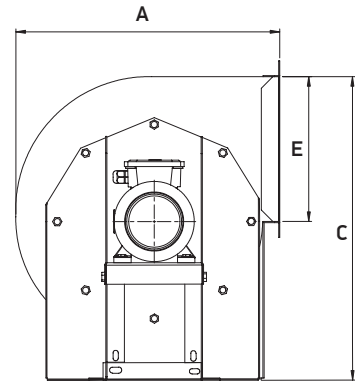
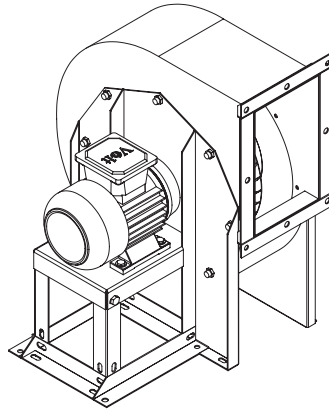
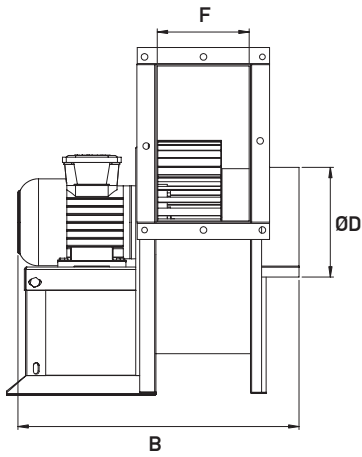

Type/Code	Sizes (mm)					
	A	B	C	D	E	F
RFAB-0,50-T-4K	470	519	583	Ø 200	250	150
RFAB-1,00-T-4K	520	574	619	Ø 200	255	185
RFAB-1,50-T-4K	566	594	725	Ø 246	270	205
RFAB-2,00-T-4K	619	634	688	Ø 260	290	225
RFAB-3,00-T-4K	660	674	912	Ø 300	315	240
RFAB-4,00-T-4K	681	716	907	Ø 300	370	250
RFAB-5,50-T-4K	755	756	891	Ø 320	400	270
RFAB-7,50-T-4K	794	855	1.017	Ø 350	460	330
RFAB-10,0-T-4K	876	905	1.041	Ø 350	545	380

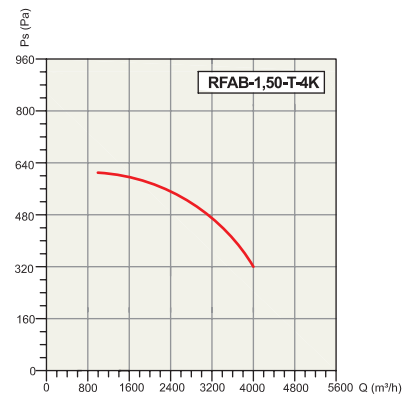
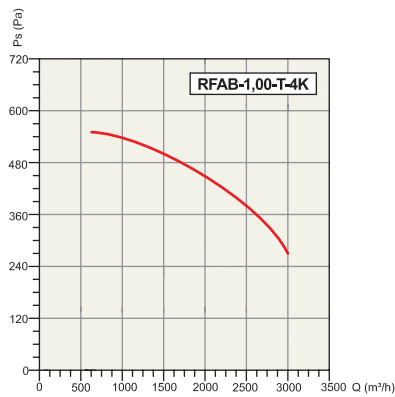
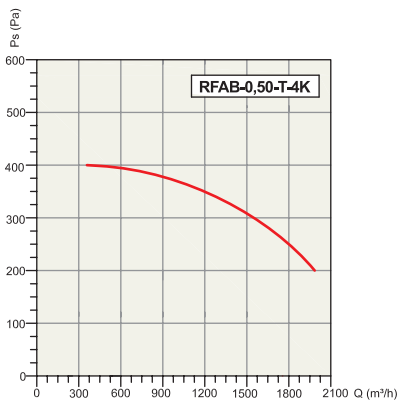

# RADIAL FANS

