

# humiFog direct

# CAREL



**ENG** User manual

**→ LEGGI E CONSERVA  
QUESTE ISTRUZIONI ←**  
**→ READ AND SAVE  
THESE INSTRUCTIONS ←**

  **NO POWER  
& SIGNAL  
CABLES  
TOGETHER**  
READ CAREFULLY IN THE TEXT!

# Contents

<b>1. INTRODUCTION</b>	<b>5</b>	<b>8. ADVANCED CONFIGURATION PARAMETERS AND OPERATING OPTIONS</b>	<b>23</b>
1.1 Intended use .....	5	8.1 Main menu and overview of functions.....	23
1.2 Disposal: information for users .....	5	8.2 Control.....	24
<b>2. SAFETY INSTRUCTIONS</b>	<b>6</b>	8.3 Functions.....	25
2.1 Purpose .....	6	8.4 Configurations .....	25
2.2 Symbols used.....	6	<b>9. MAIN/SECONDARY NETWORK OF HUMIDIFIERS</b>	<b>27</b>
2.3 Unit management.....	6	9.1 Description of the Main/Secondary system.....	27
2.4 Operation of the unit .....	6	9.2 Network switch for Main/Secondary connection.....	27
2.5 Assembly, disassembly, maintenance and repair of the unit .....	6	9.3 Type of Main/Secondary system installation .....	27
2.6 Electrical system .....	6	9.4 Main/Secondary system configuration.....	28
2.7 Disposal after decommissioning .....	6	<b>10. CONNECTIVITY</b>	<b>30</b>
<b>3. GENERAL DESCRIPTION</b>	<b>7</b>	10.1 Webserver.....	30
3.1 General description .....	7	10.2 Supervisor connection .....	31
3.2 Operating principle .....	7	10.3 List of Modbus parameters.....	31
3.3 Cabinet part numbers.....	8	10.4 List of BACnet parameters.....	32
3.4 Hose part numbers.....	8	<b>11. WIRELESS PROBES, INSTALLATION AND CONFIGURATION</b>	<b>33</b>
3.5 Blower unit part numbers.....	8	11.1 Type of installation and wireless probe electrical connections .....	33
3.6 Structure.....	9	11.2 Wireless probe installation.....	33
3.7 Dimensions and weights.....	10	<b>12. ALARM</b>	<b>34</b>
3.8 Packaging and shipment .....	10	<b>13. MAINTENANCE</b>	<b>37</b>
3.9 IP rating and standards.....	10	13.1 Hygienic aspects.....	37
<b>4. CABINET INSTALLATION</b>	<b>11</b>	13.2 Routine maintenance .....	37
4.1 Positioning.....	11	13.3 Special maintenance .....	38
4.2 Water connections.....	11	13.4 Pump maintenance .....	38
4.3 Electrical installation .....	12	13.5 50 hour oil change warning.....	39
4.4 Changing the oil cap .....	13	13.6 Notification, maintenance warning, reset hour counter.....	39
<b>5. DISTRIBUTION SYSTEM INSTALLATION</b>	<b>13</b>	13.7 Blower spare parts.....	39
5.1 Blower unit installation .....	13	13.8 Spare parts.....	40
5.2 Mounting single blower units on the wall / ceiling.....	14	<b>14. APPENDIX</b>	<b>41</b>
5.3 Mounting double blower units on the ceiling.....	14	14.1 Single-zone wiring diagram .....	41
5.4 Blower unit electrical connection .....	15	14.2 Two-zone wiring diagram.....	42
<b>6. ELECTRONIC CONTROLLER SET UP AND CONNECTIONS</b>	<b>16</b>	14.3 Datasheets.....	43
6.1 Remote ON/OFF signal connection .....	16		
6.2 Analogue signal from the main probe and limit probe in the first..... zone .....	16		
6.3 Analogue signal from the main probe and limit probe in the second . zone .....	16		
6.4 Analogue signal from an ext. controller .....	17		
6.5 Digital signal from humidistat or external controller .....	17		
6.6 Serial or Ethernet communication .....	17		
6.7 Alarm relay output.....	17		
6.8 Unit status digital output .....	17		
6.9 Production percentage analogue outputs.....	17		
<b>7. START-UP AND USER INTERFACE</b>	<b>18</b>		
7.1 Graphic terminal .....	18		
7.2 Start-up.....	18		
7.3 Touch display .....	19		
7.4 Remote installation of the touch display .....	22		

# 1. INTRODUCTION

CAREL humidifiers are advanced products, whose operation is specified in the technical documentation supplied with the product or can be downloaded, even prior to purchase, from the website [www.carel.com](http://www.carel.com). Each CAREL product, in relation to its technical development, requires setup/configuration/programming to be able to operate in the best possible way for the specific application.

Failure to complete the required analysis, as specified in the manual, or the configuration procedure, may cause the final product to malfunction; CAREL accepts no liability in such cases. The customer (manufacturer, developer or installer of the final equipment or system) accepts all liability and risk relating to the configuration of the product in order to reach the expected results in relation to the installation and/or specific final equipment. CAREL may, based on specific agreements, act as a consultant for correct installation/commissioning/operation, however in no case does it accept liability for the correct operation of the humidifier and the final installation if the warnings or suggestions provided in this manual or in other product technical documents are not heeded. In particular, as well as observing the above warnings and suggestions, the following warnings must be observed for correct use of the product:

## 1.1 Intended use

- This product complies with the European directives and other requirements as indicated in the EC declaration of conformity. It is the customer's responsibility to carefully evaluate how the product is used, in relation to the requirements concerning special environments and/or processes (e.g. heavy industry, medical, marine environments, railway, etc.), which fall outside of the conditions of use specified by CAREL.
- The environmental conditions and power supply voltage must correspond to the values specified on the rating plate.
- The product can only be used for the functions contemplated in its design. CAREL declines all liability for any improper use of the product.
- Observe the standards in force in the place where the humidifier is installed.
- The humidifier must be installed out of the reach of children and animals. Children must not be allowed to play with the appliance.
- Do not install and use the product near objects that may be damaged by water (or water condensation). CAREL declines all liability for indirect or direct damage as a result of water leaks from the humidifier.
- Do not use corrosive chemicals, solvents or aggressive detergents to clean the inside and outside parts of the humidifier, unless specifically indicated in the user manual.
- Installation, use and maintenance must be carried out by qualified personnel who are aware of the necessary precautionary measures and are able to carry out the appropriate operations.
- Only water with the characteristics indicated in this manual must be used to produce humidity.
- All work must be carried out according to the instructions specified in this manual and on the labels affixed to the appliance. All uses/modifications not permitted by the manufacturer are illegal. CAREL declines all liability for any illegal use of the product.
- Do not attempt to open the humidifier in any way other than described in the manual.
- This installation, operation and maintenance manual must be kept in paper format in a safe and easily accessible place.
- The person in charge of operating the plant must draw up a risk assessment document.
- For operation and maintenance of the humidification system, the requirements of the current VDI 6022 guideline must be observed.

CAREL adopts a policy of continual development; consequently, CAREL reserves the right to make changes and improvements to any component described in this document without prior warning. The technical specifications shown in the manual may be changed without prior warning. The liability of CAREL in relation to its products is specified in the CAREL general contract conditions (see the website [www.carel.com](http://www.carel.com)) and/or by specific agreements with customers; specifically, to the extent where allowed by applicable legislation, in no case will CAREL, its employees or subsidiaries/affiliates be liable for any lost earnings or sales, losses of data and information, damage to things or people, costs of replacement goods or services, downtime or any direct, indirect, incidental, actual, punitive, exemplary, special or consequential damage of any kind whatsoever, whether contractual, extra-contractual or due to negligence, or any other liabilities deriving from the installation or use of the product, even if CAREL or its subsidiaries/affiliates are warned of the possibility of such damage.

## 1.2 Disposal: information for users

Please read and keep these instructions.

The humidifier is made up of metal parts and plastic parts. With reference to European Union directive 2012/19/EU issued on 4 July 2012 and related national legislation, please note that:

1. Waste Electrical and Electronic Equipment (WEEE) cannot be disposed of as municipal waste but must be collected separately so as to allow subsequent recycling, treatment or disposal, as required by law;
2. users are required to take Electrical and Electronic Equipment (EEE) at end-of-life, complete with all essential components, to the WEEE collection centres identified by local authorities. The directive also provides for the possibility to return the equipment to the distributor or retailer at end-of-life if purchasing equivalent new equipment, on a one-to-one basis, or one-to-zero for equipment less than 25 cm on their longest side;
3. the equipment may contain hazardous substances: the improper use or incorrect disposal of such may have negative effects on human health and on the environment;
4. the symbol (crossed-out wheeled bin, see Figure 1), is shown on the product or on the packaging, indicates that the equipment must be disposed of separately at end-of-life;
5. if at end-of-life the EEE contains a battery (Figure 2), this must be removed following the instructions provided in the user manual before disposing of the equipment. Used batteries must be taken to appropriate waste collection centres as required by local regulations;
6. in the event of illegal disposal of electrical and electronic waste, the penalties are specified by local waste disposal legislation.

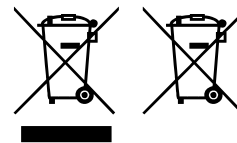

Fig.1 Fig.2

**Warranty:** the warranty does not include consumables.

**Approval:** the quality and safety of CAREL products are guaranteed by ISO 9001 certification, as well as by the  and  mark

## 2. SAFETY INSTRUCTIONS

Safety instructions are required by law. These are intended to ensure safety in the workplace and prevent accidents.

### 2.1 Purpose

To comply with the national and local regulations in force for the prevention of personal and third-party injuries.

### 2.2 Symbols used

The symbols used to represent hazards correspond to the warning messages specified in accordance with EN 82079-1 (and ANSI Z535.6):



**DANGER:** Indicates an imminently hazardous situation which, if not avoided, will result in death or serious injury.



**WARNING:** Indicates a potentially hazardous situation which, if not avoided, could result in death or serious injury.



**CAUTION:** Indicates a hazardous situation which, if not avoided, may result in light or moderate injury.

**NOTICE:** Indicates a potentially hazardous situation which may cause damage to surrounding property and equipment.

### 2.3 Unit management

Do not carry out any work that compromises the safety of the humidifier. Follow all safety instructions and warnings marked on the unit.

In the event of a malfunction or power failure, immediately switch the unit off and prevent it from being switched on again. Repair any faults promptly.



**WARNING** Reserved use.

IEC 60335-1 states the following: this appliance can be used by children aged from 8 years and above and persons with reduced physical, sensory or mental capabilities or lack of experience and knowledge if they have been given supervision or instruction concerning use of the appliance in a safe way and understand the hazards involved. Cleaning and user maintenance shall not be made by children unless they are supervised.

### 2.4 Operation of the unit



**WARNING** Burn hazard!

The humidifier contains high-temperature components. For electrode, heater or gas-fired isothermal humidifiers, in the event of leaks or component faults, uncontrolled release of steam at 100°C/212°F may be possible. Switch the unit off immediately.

Steam production is only allowed when the unit's cover is closed.

**NOTICE:** Risk of damage to the appliance!

The appliance may be damaged if switched on repeatedly following an unrepaired fault. Repair any malfunctions promptly.

The appliance must not be operated with a DC power supply.

Regularly check that all safety and monitoring devices are working properly. Do not remove or disable the safety devices.

**NOTICE:** Possibility of water leaks due to faulty connections or malfunctions.

Water is continuously and automatically fed into and drained by the humidifier. The connections and components that carry water must be regularly checked to ensure they are working perfectly.

### 2.5 Assembly, disassembly, maintenance and repair of the unit

#### NOTICE

The humidifier's protection rating is IP20. Make sure that it is not affected by dripping water in the site of installation.

Installation of the humidifier in a place without a water drainage system requires the presence of safety devices that, in the event of water leaks, can safely shut off the water supply to the humidifier.

- Only use original spare parts.
- After any repairs, make sure that safe operation of the unit is checked by qualified personnel.
- Connection or installation of additional components is only allowed with the written authorisation of the manufacturer.



**WARNING**

Do not install the humidifier on top of electrical devices such as fuse boxes, household appliances, etc. In the event of water leaks, this may damage the electrical equipment below.

### 2.6 Electrical system



**WARNING** Electric shock hazard!

Dangerous electrical voltage.

Work on the electrical system must only be carried out by qualified personnel (electrician or technician with equivalent training). During maintenance or installation work, the appliance must be disconnected from the mains power supply and must be prevented from being powered on. Electrical disconnection must be verified by measurement.

The humidifier can only be started when the cover is closed.

Water leaks may cause leakage current. Observe the safety rules when working on parts that may be live.

After electrical installation or repair work, check all safety devices (e.g. earth resistor).

#### NOTICE

Only use original fuses with the correct amperage. Regularly check the electrical parts of the equipment. Promptly repair any damage, such as loose connections, burnt wiring or defective electrical insulation.

Responsibility for intrinsically safe installation of the humidifier lies with the company that carried out installation.

### 2.7 Disposal after decommissioning

**NOTICE.** The system manager is responsible for disposal of the appliance's components as specified by law. See 1.2

### 3. GENERAL DESCRIPTION

#### 3.1 General description

humiFog Direct is a direct humidifier for room installation. It consists of a pumping unit (also called the cabinet) and a distribution system (comprising blower units) to be installed directly in the room to be humidified and cooled. The pumping unit is connected to the blower units by high pressure hoses.

The cabinet is fitted with a pump that delivers water at high pressure (70 bars) to the nozzles on the blower units, where it is atomised into very fine droplets that evaporate spontaneously.

The cabinets are available in the single zone and two-zone version. The latter can manage two independent zones, reading two separate signals (from a probe or external controller).

For all models, the minimum flow rate that can be supplied by the pump is 10% of its nominal flow rate. For this reason, it is recommended to couple a distribution line that can atomise a flow-rate of water equal at least to the minimum flow-rate delivered by the pump.

It is important to install the distribution system in a suitable environment (in terms of volume, air change and operating temperature) so as to ensure absorption of the atomised water. Carel can provide support for calculating the required humidification load.

#### 3.2 Operating principle

System operation is based on a request signal from a probe (temperature or humidity) or external controller. When the operation consent is enabled (remote ON/OFF) and at the same time there is a request for humidification or cooling, the system opens the delivery solenoid valve (see par. "Structure") and activates the pump, which pressurises the water at high pressure (70bar). After having also opened the outlet solenoid valve, the initial stage of operation begins, involving washing and filling the line, after which, when the line is filled and pressurised, the nozzles will start spraying water.

Modulation is available in PWM mode (pulse width modulation): the controller alternates a time (set on the display) in which the outlet solenoid valves are operation, thus atomising the water, with period in which the outlet valves are closed and the bypass valve is open, thus interrupting atomisation into the room.

The set point is managed directly by the electronic controller using a proportional band (P+I) or an offset when reaching the set point.

On reaching the set point, the system stops and enters standby mode, restarting when there is a new request. For this reason, the system should be powered on at all times.

#### 3.2.1 Functional diagram

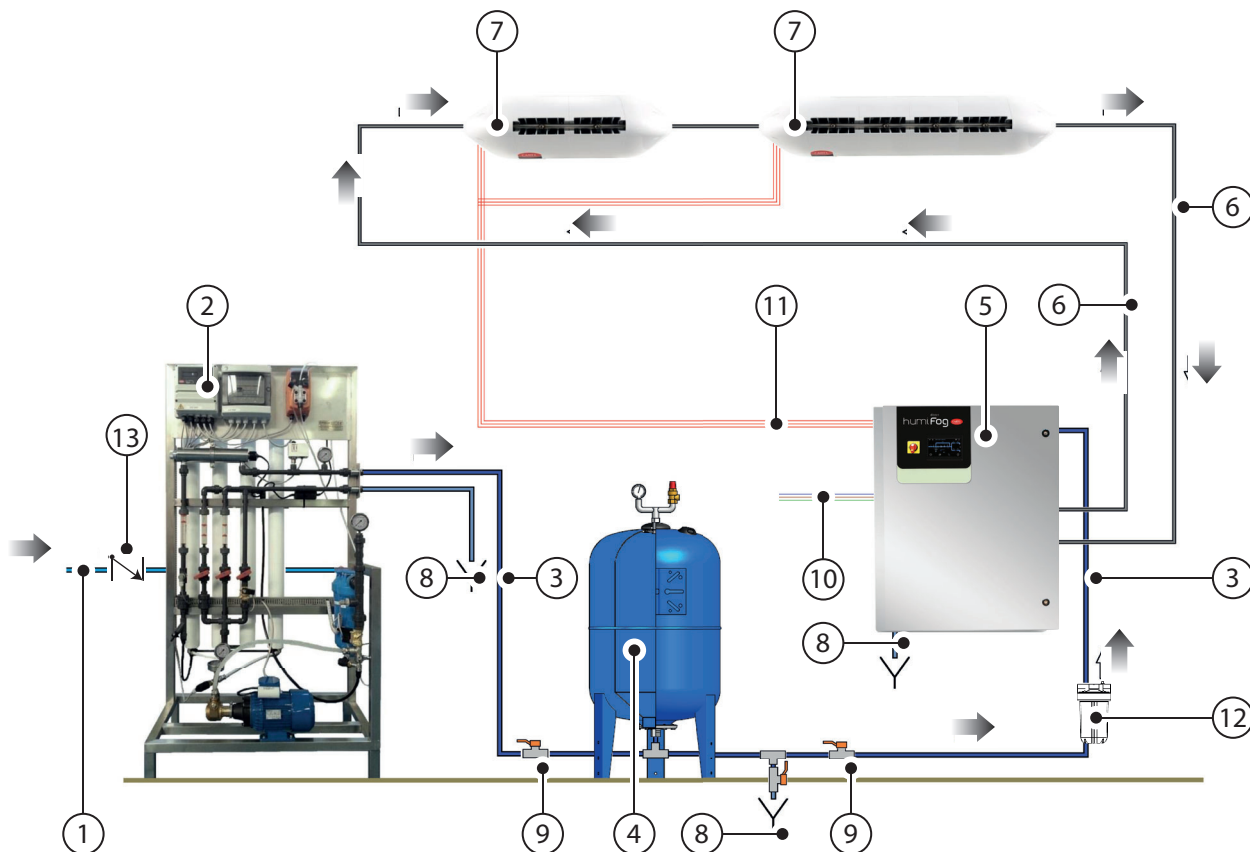

Fig. 3.a

Key

1	Mains water line
2	Reverse osmosis system
3	Demineralised water line
4	Expansion vessel
5	humiFog Direct cabinet
6	High pressure water hoses (70 bars)
7	humiFog Direct blower units

8	Water drain point
9	On-off ball valve
10	Power supply (230V 50 Hz or 120V 60 Hz)
11	Electrical connection from cabinet to the blowers
12	Mechanical feedwater filter
13	Check valve

### 3.3 Cabinet part numbers



Fig. 3.b

The cabinets differ in terms of flow-rate delivered by the pump, power supply voltage/frequency, and the capacity to control one or two atomisation racks, managed independently from each other.

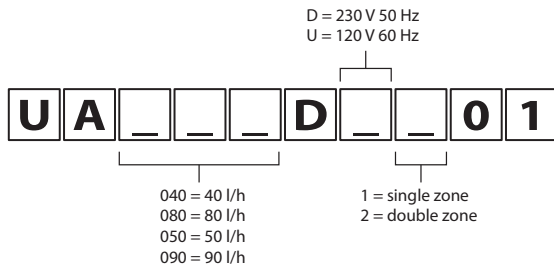

Tab. 3.a

Part numbers available:

UA040DD101	40 l/h, 230V 50Hz, single zone
UA040DD201	40 l/h, 230V 50Hz, two zones
UA080DD101	80 l/h, 230V 50Hz, single zone
UA080DD201	80 l/h, 230V 50Hz, two zones
UA050DU101	50 l/h, 120V 60Hz, single zone
UA050DU201	50 l/h, 120V 60Hz, two zones
UA090DU101	90 l/h, 120V 60Hz, single zone
UA090DU201	90 l/h, 120V 60Hz, two zones

### 3.4 Hose part numbers

The high pressure hoses (OD = 10 mm, ID = 6.4 mm) are supplied by Carel in different lengths. The part numbers available are listed below. All the hoses have with M16x1.5 female couplings with O-rings, ideal for direct connection to the cabinet and the blower units without needing to use sealants. Each hose kit includes an M16x1.5 nipple to be used for coupling different hoses together.

Stainless steel pipes can also be used to connect the blowers to the cabinet. The recommended outside diameter is 10 mm. This solution is the installer's responsibility.

Carel recommends using hoses rather than pipes.

UAKT005014	High pressure hose, L = 0.5 m
UAKT010014	High pressure hose, L = 1.0 m
UAKT020014	High pressure hose, L = 2.0 m
UAKT050014	High pressure hose, L = 5.0 m
UAKT100014	High pressure hose, L = 10 m
UAKT200014	High pressure hose, L = 20 m

Tab. 3.b

### 3.5 Blower unit part numbers



Fig. 3.c

The blower units differ based on the number of nozzles, the type of nozzles (the nozzles are already pre-assembled in the factory), power supply voltage/frequency and the direction of spray (front or two directions).

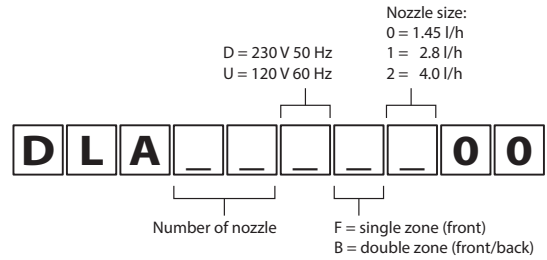

Part numbers available:

P/N	230 V 50 Hz BLOWERS (CE)
DLA02DF000	Front blower 3.0 l/h (2 x 1.45 l/h nozzles) 230 V 50 Hz
DLA02DF100	Front blower 5.0 l/h (2 x 2.8 l/h nozzles) 230 V 50 Hz
DLA02DF200	Front blower 8.0 l/h (2 x 4.0 l/h nozzles) 230 V 50 Hz
DLA04DF000	Front blower 6.0 l/h (4 x 1.45 l/h nozzles) 230 V 50 Hz
DLA04DF100	Front blower 11.0 l/h (4 x 2.8 l/h nozzles) 230 V 50 Hz
DLA04DF200	Front blower 16.0 l/h (4 x 4.0 l/h nozzles) 230 V 50 Hz
DLA04DB000	Double blower 6.0 l/h (4 x 1.45 l/h nozzles) 230 V 50 Hz
DLA04DB100	Double blower 11.0 l/h (4 x 2.8 l/h nozzles) 230 V 50 Hz
DLA04DB200	Double blower 16.0 l/h (4 x 4.0 l/h nozzles) 230 V 50 Hz
DLA08DB000	Double blower 12.0 l/h (8 x 1.45 l/h nozzles) 230 V 50 Hz
DLA08DB100	Double blower 22.0 l/h (8 x 2.8 l/h nozzles) 230 V 50 Hz
DLA08DB200	Double blower 32.0 l/h (8 x 4.0 l/h nozzles) 230 V 50 Hz

Tab. 3.c

P/N	120 V 60 Hz BLOWERS
DLA02UF000	Front blower 3.0 l/h (2 x 1.45 l/h nozzles) 120 V 60 Hz
DLA02UF100	Front blower 5.0 l/h (2 x 2.8 l/h nozzles) 120 V 60 Hz
DLA02UF200	Front blower 8.0 l/h (2 x 4.0 l/h nozzles) 120 V 60 Hz
DLA04UF000	Front blower 6.0 l/h (4 x 1.45 l/h nozzles) 120 V 60 Hz
DLA04UF100	Front blower 11.0 l/h (4 x 2.8 l/h nozzles) 120 V 60 Hz
DLA04UF200	Front blower 16.0 l/h (4 x 4.0 l/h nozzles) 120 V 60 Hz
DLA04UB000	Double blower 6.0 l/h (4 x 1.45 l/h nozzles) 120 V 60 Hz
DLA04UB100	Double blower 11.0 l/h (4 x 2.8 l/h nozzles) 120 V 60 Hz
DLA04UB200	Double blower 16.0 l/h (4 x 4.0 l/h nozzles) 120 V 60 Hz
DLA08UB000	Double blower 12.0 l/h (8 x 1.45 l/h nozzles) 120 V 60 Hz
DLA08UB100	Double blower 22.0 l/h (8 x 2.8 l/h nozzles) 120 V 60 Hz
DLA08UB200	Double blower 32.0 l/h (8 x 4.0 l/h nozzles) 120 V 60 Hz

Tab. 3.d

3.6 Structure

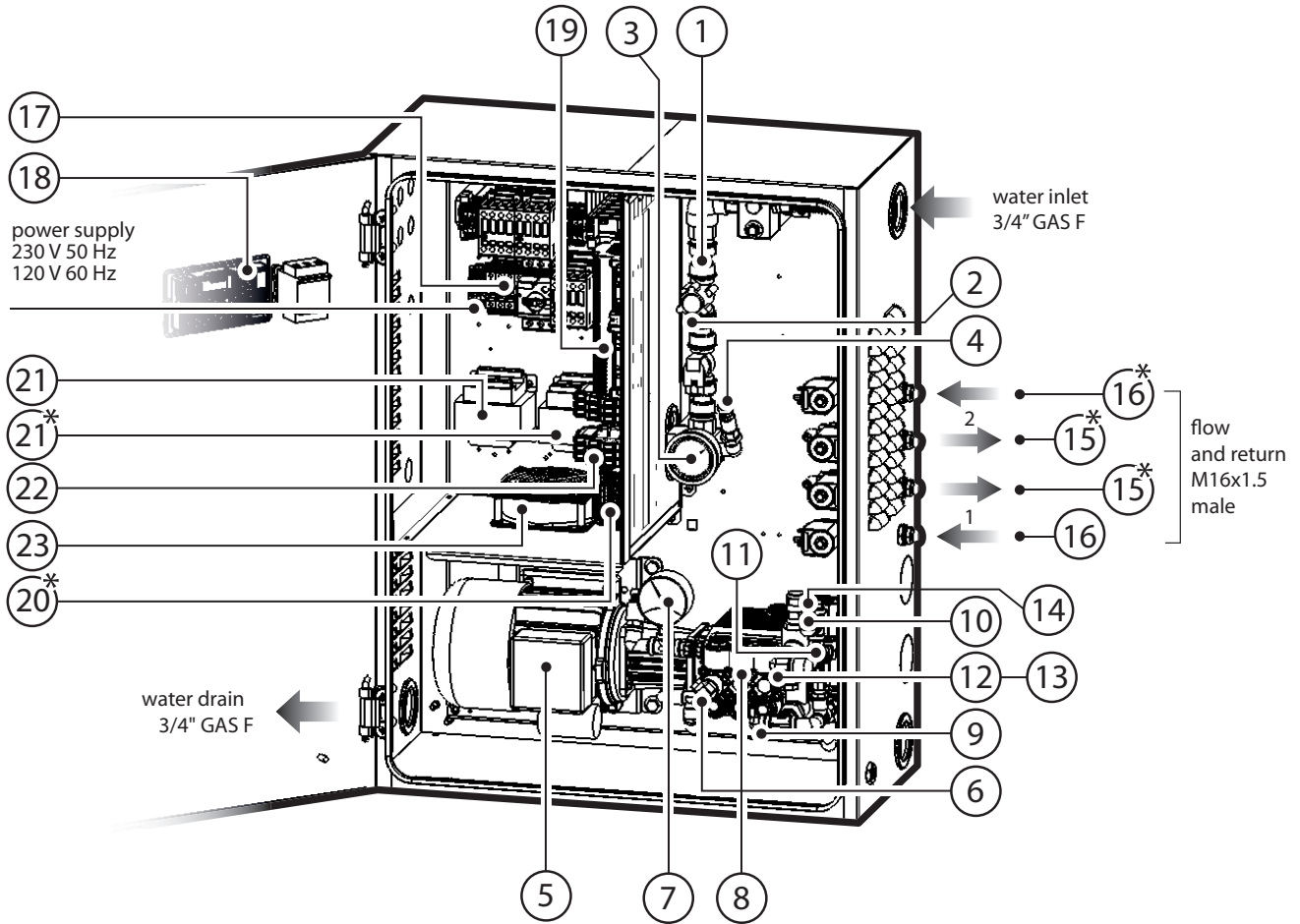

Fig. 3.d

Electrical part

Ref.	Description
1	Water inlet filter
2	Pressure reducer
3	NC fill solenoid valve
4	Low pressure gauge
5	Motor
6	Pump
7	High pressure gauge
8	High pressure sensor
9	Temperature-controlled safety valve
10	High pressure sensor
11	Temperature sensor
12	Overflow valve
13	Drain solenoid valve
14	Bypass solenoid valve
15	NC fill solenoid valve
16	NO return solenoid valve
17	Fuse kit
18	pGDx display
19	Controller
20	Expansion card
21	Transformer
22	SSR
23	Cooling fan

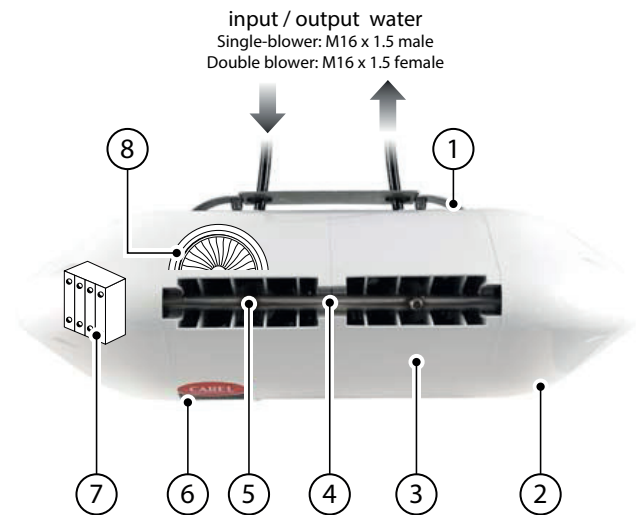

Fig. 3.e

Ref.	Description
1	metal support / wall bracket
2	side plastic cover
3	centre plastic cover
4	pressurised water manifold
5	nozzle
6	power LED
7	terminal block for blower power supply
8	fan

### 3.7 Dimensions and weights

#### 3.7.1 Dimensions and weights

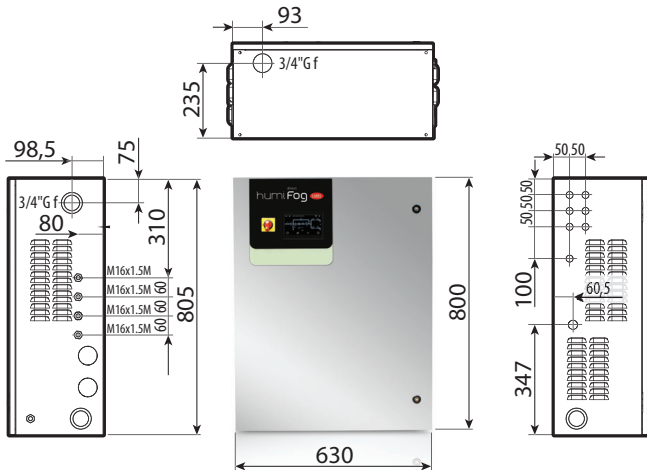

Fig. 3.f

Dimensions 630x300x800 mm (24.8"x11.8"x31.5")	Weight			
	UA040-UA050		UA080-UA090	
	single zone	two zones	single zone	two zones
	60 kg (132 lb)	64 kg (141 lb)	64 kg (141 lb)	68 kg (149 lb)

Tab. 3.e

#### 3.7.2 Dimensions and weights of the single blowers

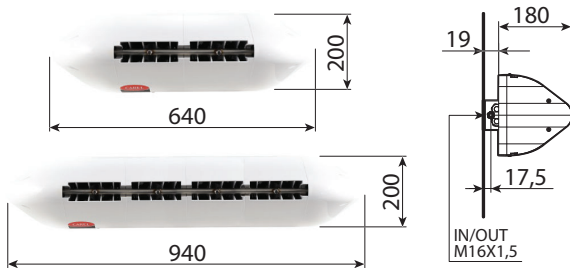

Fig. 3.g

P/N	Dimensions [a x b x c]	Weight
DLA02xFx00	640 x 200 x 180 mm (25 x 8 x 7 inches)	4.5 kg (9 lb)
DLA04xFx00	940 x 200 x 180 mm (37 x 8 x 7 inches)	5.6 kg (12 lb)

Tab. 3.f

#### 3.7.3 Dimensions and weights of the double blowers

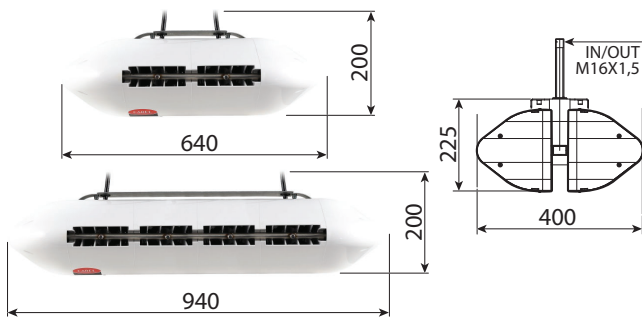

Fig. 3.h

P/N	Dimensions [a x b x c]	Weight
DLA04xBx00	640 x 200 x 400 mm (25 x 8 x 16 inches)	9.2 kg (20 lb)
DLA08xBx00	940 x 200 x 400 mm (37 x 8 x 16 inches)	15.5 kg (34 lb)

Tab. 3.g

### 3.8 Packaging and shipment

The cabinet is packaged and delivered on a wooden pallet with a cardboard cover. The user is responsible for moving the cabinet near the point of operation, removing the packaging and placing it in a position ready for the water and electrical connections.

The blowers are delivered already assembled in cardboard boxes. The user is responsible for removing the blower from the packaging, removing the side plastic covers so as to make the water and electrical connections, and then replacing the plastic covers before starting the system.

#### 3.8.1 Dimensions and weights of the packages

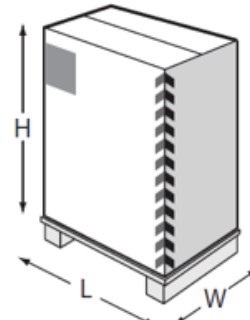

Fig. 3.i

Dimensions 720x460x1020 mm (28.5"x18"x40")	Weight			
	UA040-UA050		UA080-UA090	
	single zone	two zones	single zone	two zones
	64 kg (141 lb)	68 kg (149 lb)	68 kg (149 lb)	72 kg (158 lb)

Tab. 3.h



Fig. 3.j

P/N	Dimensions [L x W x H]	Weight
DLA02xFx00	755 x 235 x 295 mm (30 x 9 x 12 inches)	5.7 kg (12 lb)
DLA04xFx00	1050 x 235 x 295 mm (41 x 9 x 12 inches)	7.4 kg (16 lb)
DLA04xBx00	755 x 470 x 295 mm (30 x 18 x 12 inches)	11.4 kg (25 lb)
DLA08xBx00	1050 x 470 x 295 mm (41 x 18 x 12 inches)	18 kg (39 lb)

Delivery and storage temperature must be between -10°C - 50°C and humidity between 0% - 90% non-condensing.

### 3.9 IP rating and standards

The IP rating of the cabinet is IP20.

The IP rating of the blowers is IP20.

The IP rating of the blowers is not a problem for installation, as all the components inside have a higher IP rating.

The blowers can in fact be installed in rooms with very high humidity (up to 95% non-condensing).

The unit is compliant with the Machinery Directive.

The unit is CE marked in the 230 Vac 50 Hz version in accordance with IEC 60335-1, IEC 60335-2, EN 60335, EN 61000-6-2 (2006) and EN 61000-6-4 (2007).

The unit is UL marked in the 120 Vac 60 Hz version in accordance with directive UL998.

## 4. CABINET INSTALLATION

### 4.1 Positioning

As the pumping station is IP20, it must be located in a roofed technical room, protected from rain, splashing, direct sunlight and any source of heat. The temperature/humidity sensors required to control the humidifier must not be affected by misting and they must be placed away from direct sunlight and any heat source.

The cabinet must be installed in an environment with a temperature between 5 and 40°C.

Around 1 m clearance must be left in front of the cabinet to allow the door to be opened and maintenance to be performed. At the sides, a free space of about 0.5 m (on both sides) must be provided, in order to allow for the hydraulic connections on the right and the electrical connections on the left.

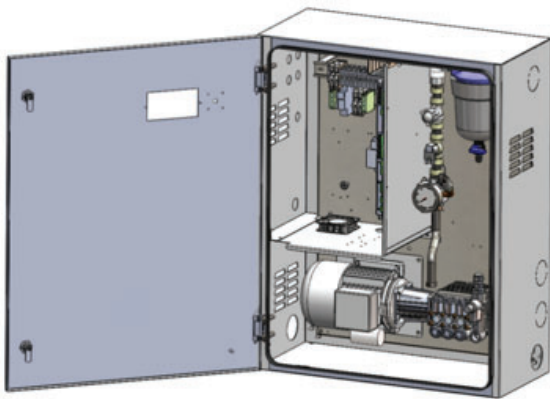

Fig. 4.a

#### 4.1.1 Wall mounting

The cabinets can be wall-mounted or floor-standing. In the event of wall mounting, it is recommended to use the metal frames and screws supplied. See the distances shown in the following image for drilling the holes and fastening the brackets.

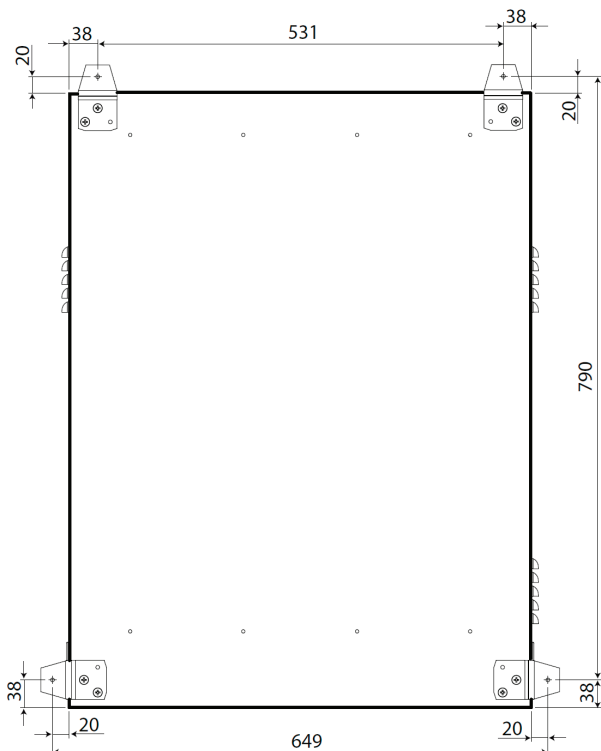

Fig. 4.b

#### 4.1.2 Floor-standing installation

For floor-standing installation, the unit needs to rest on a raised platform so as to allow connection of the drain hose, located on the bottom of the cabine (see par. "Cabinet drain connection").

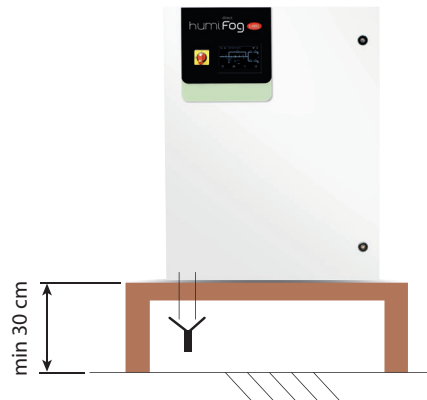

Fig. 4.c

### 4.2 Water connections

**⚠ WARNING: electric shock hazard.**

Before making the electrical connections, the appliance must be disconnected from the mains power supply and must be prevented from being powered on. Electrical disconnection must be verified by measurement.

**NOTE:** observe the local regulations for connecting the system to the drinking water supply (see VDI/DVGW 6023, DIN EN 1717 and DIN 1988-100).

#### 4.2.1 Feedwater line

An expansion vessel should always be installed upstream of the cabinet, so as to attenuate variations in pressure in the feedwater line. It is also suggested to install a mechanical filter on the feedwater line to the cabinet (P/N ECKVESS050 for the filter vessel and P/N ECKFILT050 for the filter cartridge). Finally, an on-off ball valve should be installed on the line upstream of the cabinet, so as to allow for any maintenance operations on the water circuit downstream.

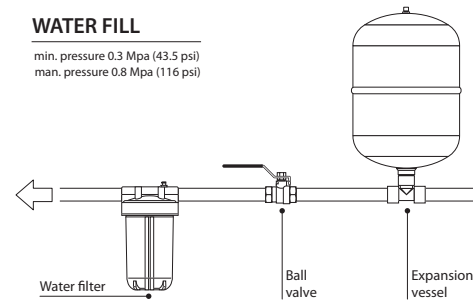

Fig. 4.d

A hose with a minimum diameter  $\varnothing=1/2"$  should be connected upstream of the cabinet so as to ensure the right flow-rate and pressure to the humidifier. The humidifier inlet connection is  $3/4"$  GAS F. The required humidifier inlet pressure is at least 3 bars.

**📌 NOTICE:** for the Australian market and to comply with Watermark requirements, a watermarked approved dual check valve shall be installed in the supply line to the humidifier when connected to potable water. Should on the other hand the humidifier be fed with treated water from a Carel reverse osmosis system connected to potable water, the dual check valve shall be installed in the supply line to the reverse osmosis system.

**4.2.2 Feedwater characteristics**

humifog Direct requires demineralised water, so as to ensure:

- minimum maintenance;
- no blockages of the nozzles;
- no dust (the droplets that evaporate will not leave mineral salts in the environment);
- improved hygiene.

The use of demineralised water is also required to comply with standards UNI8883, VDI6022 and VDI3803.

humifog Direct must only operate on demineralised water that falls within the limits listed in the following table. Normally, these values can be obtained by reverse osmosis or nanofiltration of the feedwater.

Ion exchange softening is not recommended, as it is ineffective in removing salts and as it can cause microbial contamination.

Temperature	5 ÷ 20°C (41 ÷ 68°F)
Specific conductivity	25 ÷ 80 µS/cm
ph	5.5 – 8.5
Total hardness (TH)	0 ÷ 25 mg/l CaCO <sub>3</sub>
Temporary hardness	0 ÷ 15 mg/l CaCO <sub>3</sub>
Chlorides (Cl)	0 ÷ 10 ppm Cl
Iron + manganese (Fe + Mn)	0 mg/l
Silicon dioxide (SiO <sub>2</sub> )	0 ÷ 1 mg/l
Chlorine ions (Cl <sup>-</sup> )	0 mg/l
Calcium sulphate (CaSO <sub>4</sub> )	0 ÷ 5 mg/l

With regard to microbiological parameters, the water used must be of drinking quality. If it is not possible to keep the water temperature below 20°C (68°F), appropriate measures must be provided for in the risk assessment document by the person in charge of running the system.

**4.2.3 Cabinet drain connection**

The drain point located at the bottom of the cabinet must be connected externally (3/4" GAS F fitting) to an open discharge with drain trap.

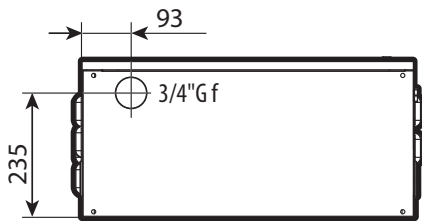

Fig. 4.e

Also remember that the cabinet cannot be installed on the floor without a support that keeps the cabinet raised by at least 20-30 cm.

**NOTICE:** the drain water must be able to flow freely.

**4.2.4 Blower water supply line**

With reference to the high-pressure hoses provided by CAREL (inside diameter Ø = 6.3 mm), in order to ensure correct operation of the atomisation system, the water supply line to the blowers in a single zone must respect the following maximum lengths:

Model	Rated pump capacity [L/h]	Maximum hose length supplying the blowers* [m]
UA040DD2**	40	25
UA050DU2**	50	
UA040DD1**	40	50
UA050DU1**	50	
UA080DD2**	80	50
UA090DU2**	90	
UA080DD1**	80	100
UA090DU1**	90	

Tab. 4.a

\* The values shown refer to the water circuit in a single zone and the last blower on the line.

Contact CAREL for longer water lines.

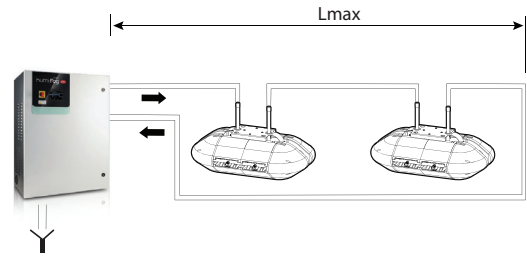

Fig. 4.f

**4.3 Electrical installation**

**⚠ WARNING:** electric shock hazard. Dangerous electrical voltage.

Before making the electrical connections, the appliance must be disconnected from the mains and secured against restarting. Electrical disconnection must be ensured by means of a measurement.

The user is responsible for connecting the pumping station to the power supply.

230 V 50 Hz for CE version UA\*\*\*DD\*01

120 V 60 Hz for UL version UA\*\*\*DU\*01

The connection must be made in accordance with local regulations, using a suitable cable cross-section. A three-core cable (phase + neutral + earth) must be connected to the three terminals (L + N + GR).

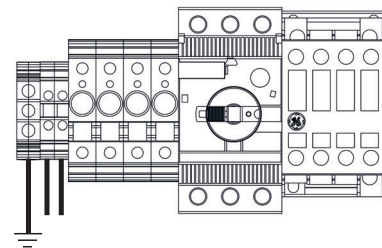

Fig. 4.g

Cabinet terminal	Power cable
L	L / F (line)
N	N / W (neutral)
GR	GR / PE (earth)

**Important:** fit an external power switch on the humidifier power supply line to isolate the power supply, and a TT earthing system with earth fault current of 30 mA.

No additional wiring is required to the cabinet terminal block, except for the power supply to the blower fans, using the terminals. For the electrical connections from the cabinet to the blowers, see par. "Blower unit electrical connection".

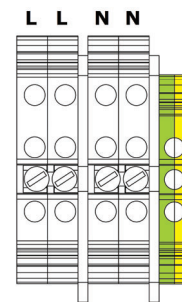

Fig. 4.h

4.3.1 Fuses

The following table lists the technical specifications of the fuses supplied for the different cabinets:

UA0*ODD*** (50 Hz)	Fuse	Single-zone cabinet	Two-zone cabinet
	F1	1 A (upstream of the transformer)	1 A (upstream of the transformer)
F2	1 A (upstream of the transformer)	1 A (upstream of the transformer)	1 A (upstream of the transformer)
F3	4 A (downstream of the transf.)	4 A (downstream of the transf.)	1 A (upstream of the transformer)
F4			1 A (upstream of the transformer)
F5			4 A (downstream of the transf.)
F6			4 A (downstream of the transf.)

UA0*ODU*** (60 Hz)	Fuse	Single-zone cabinet	Two-zone cabinet
	F1	2.5A (upstream of the transformer)	2.5A (upstream of the transformer)
F2	2.5A (upstream of the transformer)	2.5A (upstream of the transf.)	2.5A (upstream of the transf.)
F3	4 A (downstream of the transf.)	2.5A (upstream of the transf.)	2.5A (upstream of the transf.)
F4			2.5A (upstream of the transf.)
F5			4 A (downstream of the transf.)
F6			4 A (downstream of the transf.)

Tab. 4.b

Fuses F1, F2, F3\*, F4\* are positioned on the fuse holders (Fig.4.i).  
 Fuses F3, F5\*, F6\* are positioned on the upper surface of the respective transformers (components no. 17 in the figure in para. "Structure").  
 \* indicates the fuse rating of the dual zone pumping station.

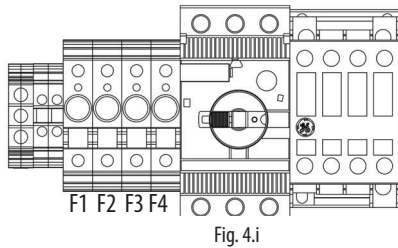

4.4 Changing the oil cap

During installation, before starting the unit, remember to replace the red oil cap (A) on the pump with the yellow one (B) supplied. The red cap is closed and is only used for transport. The yellow cap has a vent opening and is used for normal operation of the system. The yellow cap is supplied inside the cabinet, tied to the high pressure gauge (see the image below).

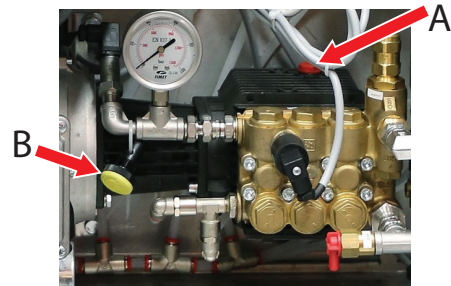

Fig. 4.j

5. DISTRIBUTION SYSTEM INSTALLATION

5.1 Blower unit installation

The humiFog Direct system works by connecting the cabinet to a number of blower units installed directly in the room to be humidified and/or cooled.

The following simple rules must be kept in mind when installing the blower units:

- the minimum flow-rate that can be atomised in the room is 8 l/h (irrespective of the size of the pump). The minimum number of blower units must therefore be defined based on the number and size of the chosen nozzles.

The maximum numbers of blower units that can be connected to a cabinet are:

- 12 blower units with 2 nozzles
- 6 blower units with 4 nozzles
- 3 blower units with 8 nozzles

The blower units must be suitably positioned so as to allow complete absorption of the sprayed water. Consequently it is recommended to install the blowers a due distance apart, at a sufficient height from the floor and with free space at the front without obstacles.

Do not install the head units in recesses, closed corridors or behind curtains, as this would hinder the uniform diffusion of humidified air. At the fan heads the air is cooler and more humid and the noise emission of nozzles and fans must be taken into consideration. Position the heads so as not to cause discomfort to the occupants of the room. Do not install in areas where the air is contaminated, particularly by microorganisms or allergens.

The blower units can be mounted either on the wall or on the ceiling.

For a correct installation, see the example or contact Carel for different temperature and humidity conditions.

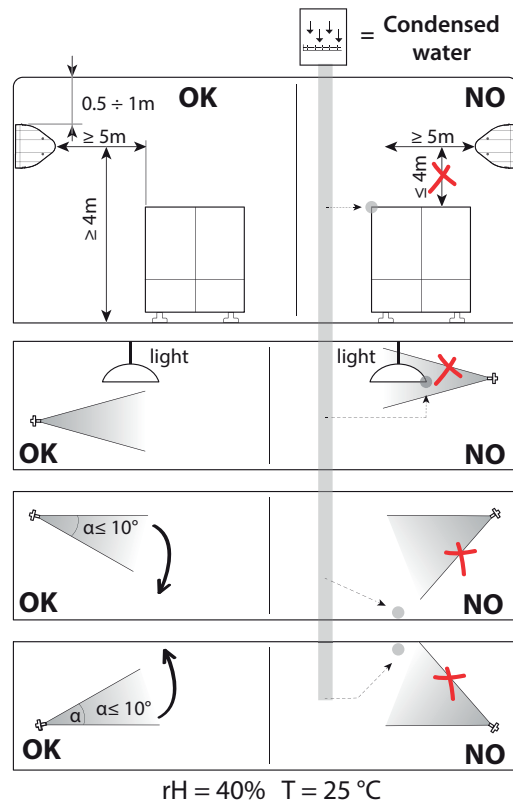

Fig. 5.a

The blower unit installation procedure is as follows:

1. Unpack the blower unit from the box it was delivered in. The blower units are delivered fully assembled.
2. Remove the side plastic covers cover from the blower. Unscrew the long screws on the side using a screwdriver. Make sure to keep the screws, as they will be needed again for assembly at the end.
3. Mount the blower unit on the metal support. See paragraph "Mounting single blower units on the wall / ceiling".
4. Connect the water line to the inlet on the blower units (M16x1.5). See paragraph "Mounting single blower units on the wall / ceiling".
5. Electrically connect the blower units to the cabinet, which supplies power and controls operation of the fans. See paragraph "Blower unit electrical connection".
6. Complete blower assembly by repositioning the side plastic covers removed previously, and fixing them with the same screws as removed at the beginning.

## 5.2 Mounting single blower units on the wall / ceiling

The single blower units (P/N DLA%F) are designed to be installed on a vertical wall using a special metal support to be fixed to the wall using screws. Check that the wall is made from suitable material and is able to support the weight of the blower unit (concrete, not plasterboard).

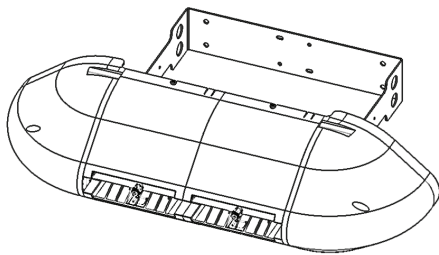

Fig. 5.b

First remove the blower unit from the packaging and take off the side plastic covers. Remove the blower unit from the steel bracket on the rear.

Rest the bracket against the wall in the position where the blower will be installed, and then drill four holes in the wall, using the steel bracket as the drilling template.

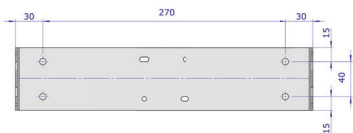

Fig. 5.c

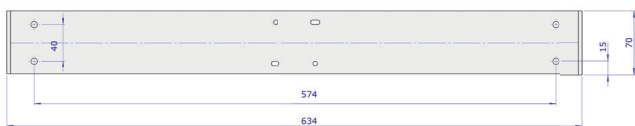

Fig. 5.d

After having drilled the holes in the wall, fix the metal support using anchor screws (not supplied).

Then attach the blower to the protrusions on the wall-mounting support bracket.

Fix the blower unit to the bracket using the screws supplied in a bag inside the packaging.

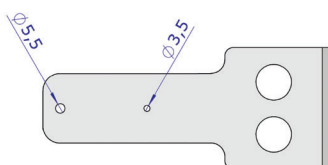

Fig. 5.e

When tightening the first screw (M6 self-tapping in  $\varnothing=5.5$  mm holes), slightly loosen the screws on the ring clamps that support the nozzle manifold, so as to be able to turn it and free up space to continue mounting the unit. Tighten one screw on the right and one screw on the left.

Then tighten the third screw (M4 self-tapping in  $\varnothing=3.5$  mm hole) on the right-hand side of the blower (opposite the terminal block). When tightening this screw, the angle of the blower can be adjusted between  $-10^\circ/-5^\circ/0^\circ/+5^\circ/+10^\circ$  from horizontal, using one of the five small holes provided.

Then make the water connections, connecting the feedwater line either on the right or left of the blower, and the water return line on the opposite side.

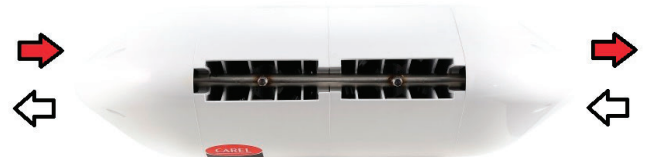

Fig. 5.f

Finally, fit the two cable glands and complete the electrical wiring, as described in paragraph "Blower unit electrical connection".

Carel also provides an additional kit (including a special plate bent at  $90^\circ$ ) for mounting single blower units on the ceiling.

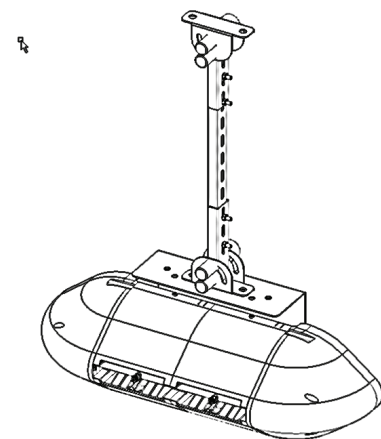

Fig. 5.g

## 5.3 Mounting double blower units on the ceiling

The double blower units (P/N DLA%B) are designed to be installed on the ceiling by anchoring them to a metal support that can support their weight and the vibrations due to the pressurised water. To mount the blower unit, use the special attachments provided on the unit's metal structure.

Carel provides additional kits with everything needed to complete installation easily. Make sure to carefully choose the point where the vertical support bar will be anchored. The support bar must not be longer than 1 metre, so as to avoid excessive bending and vibrations.

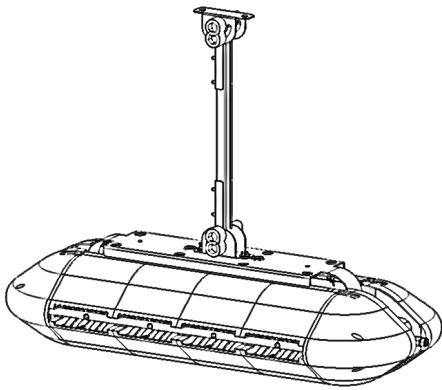

Fig. 5.h

After installing the blower, make the water connections by connecting the feedwater and return lines to the two pipes provided on the top of the blower. The feedwater/return lines can be connected either to the right or left.



Fig. 5.i

Finally, fit the two cable glands and complete the electrical wiring, as described in paragraph "Blower unit electrical connection".

### 5.4 Blower unit electrical connection

The blower units must be electrically connected to the cabinet so that they are activated only when there is a humidification request. The necessary cable fittings are included in the delivery.

Before electrically connecting the blower units to the cabinet, make sure that the cable glands supplied with the cabinet and the blower units are available. All connections to be made by the user (cabinet power supply, blower unit power supply, probe connections, etc.) must be performed by running the cables through the cable glands, and in accordance with local safety standards.

Also check that the cable is the right size for the distance and voltages used. Carel recommends an AWG14 or AWG12 cable, as shown in the technical data at the end of the manual.

To connect power to the blower units, connect three suitably-sized wires (line + neutral + earth) from the terminals on the cabinet (shown in the figure) to the terminals on the blower (shown in the figure). To power a second and subsequent blowers, start from the free terminals on of the previous blower and connect to the terminals on the next blower, as shown in the figure.

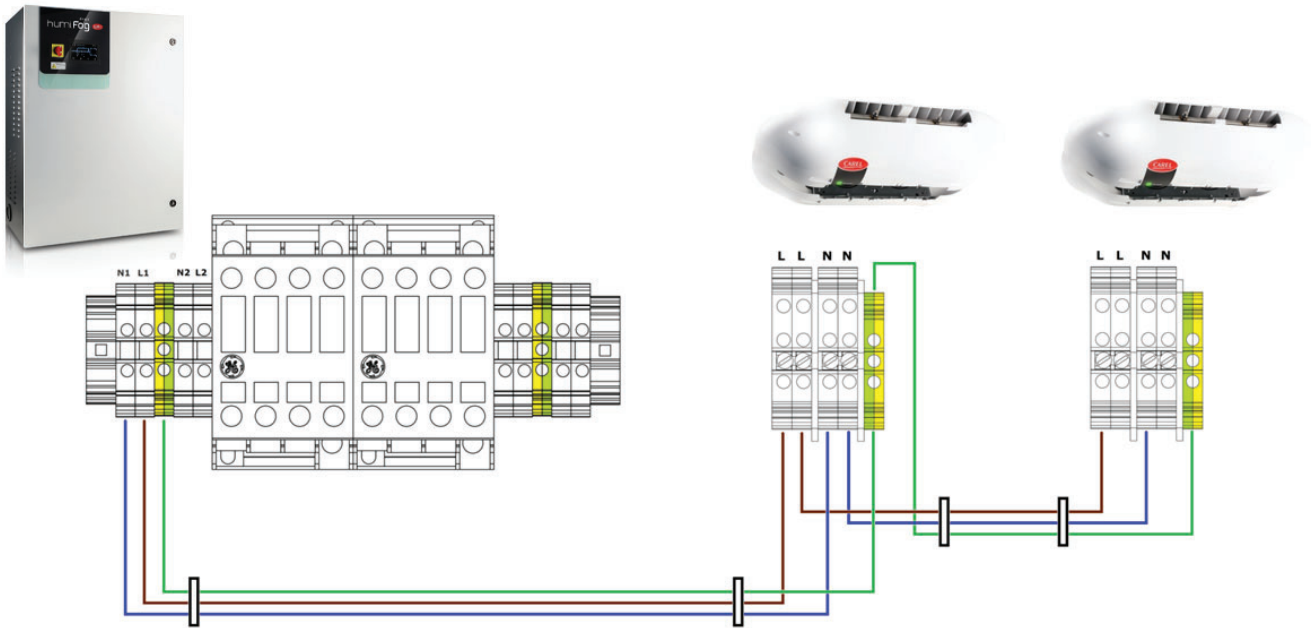

Fig. 5.j

**Important:**

- remember to run the wires through the cable glands (marked in the figure).
- check the maximum number of blower units that can be connected to each cabinet in the tables in Appendix 12 at the end of the manual.
- when connecting the line (L) and neutral (N) from the cabinet to the blower units, never reverse L and N. Reversing or crossing over the wiring may cause short-circuits.

After having completed the wiring, close the side plastic covers again and fix them using the screws. The system is now ready to operate.

## 6. ELECTRONIC CONTROLLER SET UP AND CONNECTIONS

After having correctly installed the cabinet and completed the water and electrical connections, connect the signals used to interface with the humiFog Direct humidifier to the c.pHC electronic controller (and the c.pCO controller on two-zone cabinets).

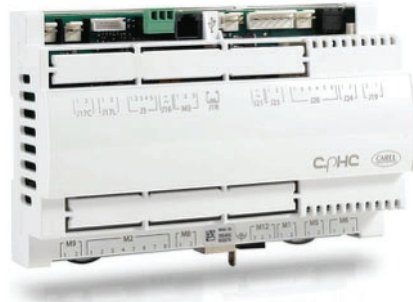

Fig. 6.a

### 6.1 Remote ON/OFF signal connection

The remote ON/OFF contact is used to enable operation from an external device. It is a digital contact that can be either open or closed: when the terminal is open, humiFog cannot operate. The contact refers to inputs 7 [GND]- 8 [digit] on terminal M2 on the c.pHC. The remote ON/OFF contact must not be confused with the ON/OFF signal that manages operation, described in paragraph "Digital signal from humidistat or external controller".

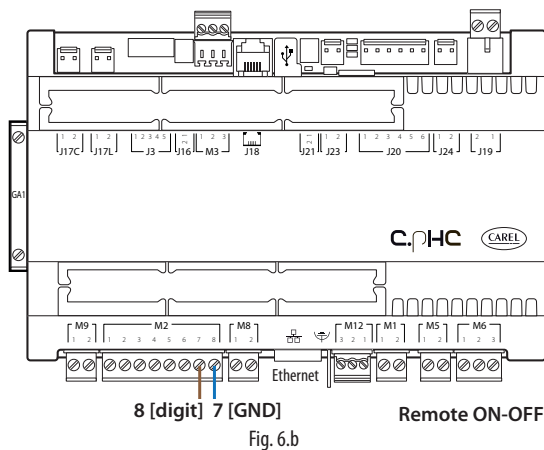

Fig. 6.b

If not intending to use an external contact to start / stop the unit, leave the terminal short-circuited (as supplied).

### 6.2 Analogue signal from the main probe and limit probe in the first zone

humiFog Direct can be controlled using an analogue signal (modulating) from a main humidity or temperature probe connected to the c.pHC electronic controller. If connected to a humidity probe, humiFog Direct will display the relative humidity read by the probe. If connected to a temperature probe, on the other hand, humiFog Direct will display the temperature. Based on the probe reading and the deviation from the set point, humiFog Direct will modulate the humidification load according to the PWM principle (see paragraph "Control"). The following types of probes are allowed:

- 4-20 mA, 0-20 mA current probes
- 0-10 V, 0-1 V, 2-10 V voltage probes

The analogue signal from the main probe in the first zone is connected to the c.pHC controller via inputs 1 [IN a] 2 [GND] 3 [+12 Vdc] on terminal M2.

The limit probe (optional) is used for the auxiliary function to reduce humiFog Direct humidification or cooling capacity when approaching a set humidity or temperature threshold (on the display or external controller). To set the threshold, select operation with limit probe on the

display. The threshold will either be a humidity or temperature value. The limit probe can also be used without using a main probe.

The following types of probes are allowed:

- 4-20 mA, 0-20 mA current probes
- 0-10 V, 0-1 V, 2-10 V voltage probes

The analogue signal from the limit probe in the first zone is connected to the c.pHC controller via inputs 5 [IN a] 6 [GND] 3 [+12 Vdc] on terminal M2.

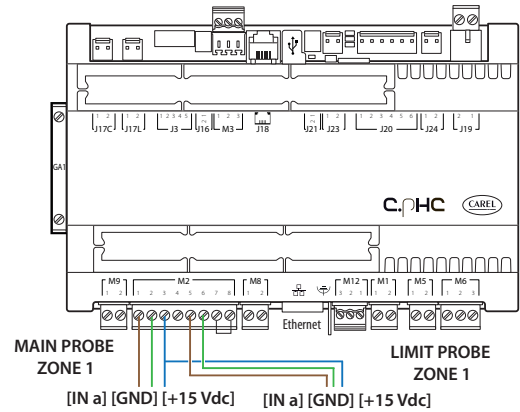

Fig. 6.c

**Important:** if connecting a probe with voltage signal that requires a power supply greater than the +12 Vdc supplied to the terminal on the c.pHC, the third wire must not be connected to input 3 [+12 Vdc] but rather to terminal GA1 [+24 Vac], made available on the cabinet terminal block, right above the c.pHC.

### 6.3 Analogue signal from the main probe and limit probe in the second zone

If a second zone is used (only with UA%DD201 and UA%DU201 cabinets), the main probe corresponding to the second zone must be connected to the c.pCOe expansion installed under the c.pHC controller.

The following types of probes are allowed:

- 4-20 mA, 0-20 mA current probes
- 0-10 V, 0-1 V, 2-10 V voltage probes

The inputs used for the main probe are U1 [IN a] and [GND] on terminal J2, and the power supply is taken from the +Vdc on terminal J9. The limit probe (optional) corresponding to the second zone is connected to inputs U2 [IN a] and [GND] on terminal J2, and the power supply is taken from the +Vdc on terminal J9.

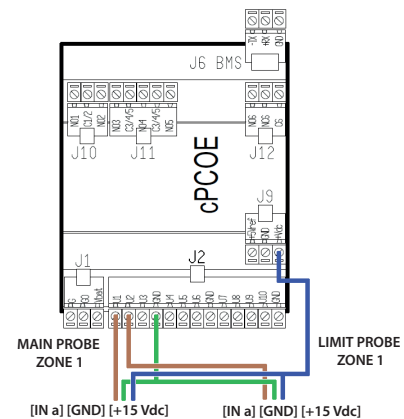

Fig. 6.d

**Important:** unlike the first zone, the connection to the c.pCOe expansion relating to the second zone can supply power to probes that require up to 21 Vdc.

### 6.4 Analogue signal from an ext. controller

As an alternative to the main probe, a signal from an external controller can be used. The latter processes the request to send to humiFog Direct via an analogue signal, which varies from 0 to 100%. humiFog will adjust the capacity delivered proportionally to the signal received, and the display will show the request sent as a percentage.

The following types of proportional signals are allowed:

- 4-20 mA, 0-20 mA current signals
- 0-10 V, 0-1 V, 2-10 V voltage signals

The external signal for the first zone is connected to the c.pHC controller via inputs 1 [IN a] and 2 [GND] on terminal M2.

The external signal for the second zone is connected to the c.pCOe controller via inputs U1 [IN a] and [GND] on the terminal J2.

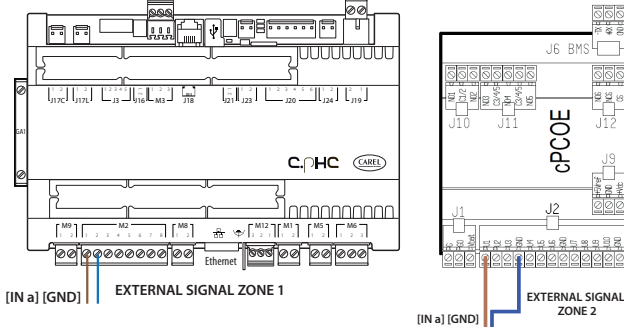

Fig. 6.e

Fig. 6.f

The limit probes can also be associated with the external proportional signal, and will be connected as shown in the previous paragraphs. For the first zone to c.pHC control: inputs 5, 6 and 3 to M2 connector. For the second zone to the c.pCOe expansion card: U2 and GND of connector J2 and voltage supply to Vdc terminal of connector J9.

### 6.5 Digital signal from humidistat or external controller

The signal from the external controller can be replaced by the signal from a humidistat, thermostat, or any external device with digital contact. In this case, humiFog Direct will work in ON/OFF mode, either delivering 100% of flow-rate or remaining in standby. The capacity delivered can be reduced by setting parameter P0 (the reduction is managed by PWM, see paragraph "Settings"). The electrical connection is the same as in the previous case (see figure in para. "Analogue signal from external controller"). **WARNING:** configure the setting of humiFog Direct (via display screens), so that it can be controlled by an ON/OFF signal from an external controller or device.

### 6.6 Serial or Ethernet communication

humiFog Direct can be controlled by a supervisor that reads the humiFog Direct parameters and sends commands. To connect a supervisor, the RS485 serial port (terminal M12, inputs 1 [Tx/Rx-] 2 [Tx/Rx+] 3 [GND]) or Ethernet port is used. The choice of which port to use depends on the supervisor. Modbus and BACnet communication protocols are available as standard: no auxiliary cards need to be fitted on the c.pHC controller

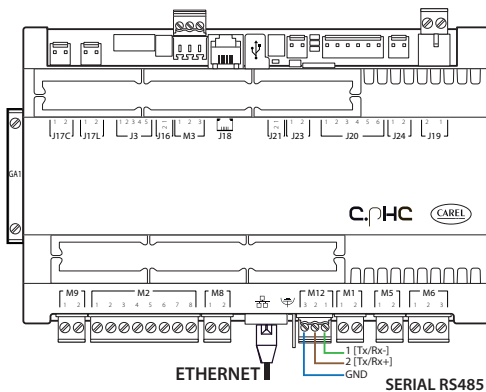

Fig. 6.g

The Ethernet port can also be used for the Webserver function (see cap. "Connectivity"), so as to monitor and control humiFog Direct via a local network, without needing a supervisor.

### 6.7 Alarm relay output

The digital output for communication of an alarm status is connected to contacts 1-2-3 on terminal M6 on the c.pHC. N.C. logic is set by connecting the two wires to contacts 1-2, while N.O. logic is set connecting the two wires to contacts 1-3.

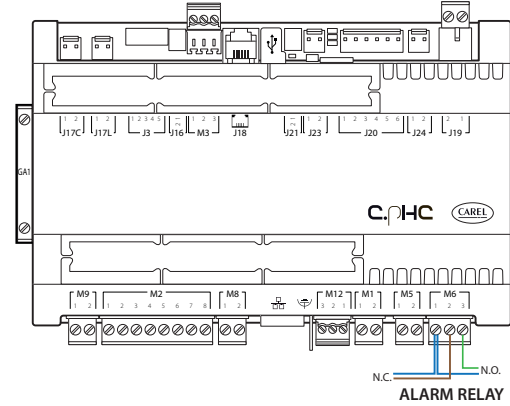

Fig. 6.h

### 6.8 Unit status digital output

The c.pHC controller provides a digital output corresponding to unit status. This is a voltage-free contact that provides the following information:

- contact closed: unit on or in standby
- contact open: unit off (OFF from keypad or from remote contact, or no power)

The unit status digital output is available at contacts 1-2 on terminal M5 on the c.pHC.

### 6.9 Production percentage analogue outputs

The c.pHC controller provides an analogue output (0-10V) corresponding to the percentage of production that humiFog Direct is delivering. The output replicates the request signal relating to the corresponding humiFog Direct zone.

The production percentage analogue outputs are connected to the following terminals:

- zone 1: outputs 1 and 2 on terminal M8 on the c.pHC.
- zone 2: outputs U3 and GND on terminal J2 on the c.pCOe.

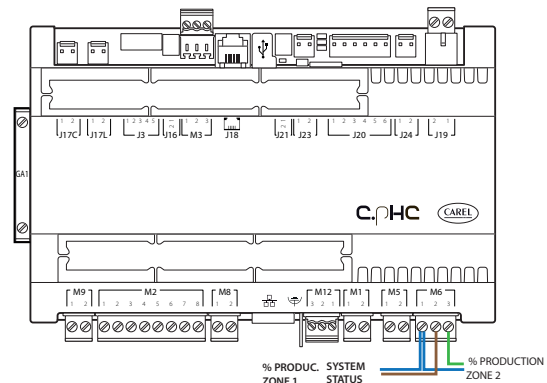

Fig. 6.i

**Important:** when several GND contacts are wired to the same terminal these are equivalent to each other, and can be used indifferently.

## 7. START-UP AND USER INTERFACE

### 7.1 Graphic terminal

The 4.3" touch graphic terminal has an interface with coloured and animated icons. The contents of the display can be scrolled up and down simply and intuitively.

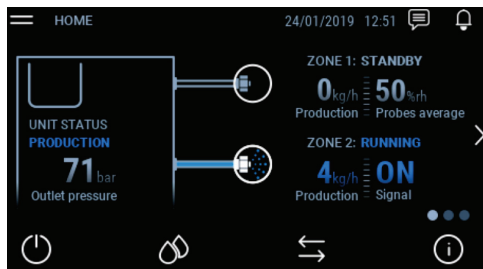

Fig. 7.a

On the right of the graphic terminal is the notification bar. If the humidifier is powered on, the notification bar is always on, even when the display is off, and provides immediate information on humidifier status.

Bar colour	Bar status	Humidifier status
White	Light on steady	Unit off (off or standby)
Green	Light on steady	Unit in production, start-up, fill
Blue	Light on steady	Washing in progress
Red	Light flashing	Alarm on the unit
Cyan	Light on steady	Unit in manual mode
Yellow	Light flashing	Unit shutting down

Tab. 7.a

### 7.2 Start-up



Switch on humiFog Direct by moving the disconnect switch on the front panel from position O to position I.

The display shows the "humiFog Direct" logo, after which the menu language can be chosen, from the following options:

- English
- Italiano
- Deutsch
- Français
- Español

Tap the language and flag icon with your finger to access the drop-down menu with the options.



Fig. 7.b

Scroll the menu with your finger.

Select the desired language and then confirm.



Fig. 7.c

#### Configuration wizard

When starting the first time, a wizard is provided to quickly set the main unit parameters. There are at most 10 steps to set up the unit:

##### Step 1/10

Enter the humidifier model.

##### Step 2/10

Enter the humidification load in kg/h for zone 1 and, if present, zone 2. The humidification load can be easily calculated by multiplying the number of atomising nozzles in the zone by the flow-rate delivered by each nozzle.

##### Step 3/10

Select zone 1 control mode from the options:

- ON/OFF contact (e.g. humidistat);
- External signal;
- External signal + humidity limit probe;
- External signal + temperature limit probe;
- Main humidity probe;
- Main temperature probe;
- Main humidity probe + humidity limit probe;
- Main temperature probe + temperature limit probe;
- Main humidity probe + temperature limit probe;
- Main temperature probe + humidity limit probe;
- Two main humidity probes (weighted average);
- Two main temperature probes (weighted average);

If using wireless probes, select the parameter that is shown by default and at the end of the wizard refer to chapter "9. WIRELESS PROBES; INSTALLATION AND CONFIGURATION".

##### Step 4/10

Select zone 2 control mode. The options available are those already listed in step 3/10.

##### Step 5/10

Select the type of signal from the main probe or from an external controller to control zone 1:

- 0-10 V;
- 4-20 mA;
- 0-20 mA;
- 0-1 V;
- 2-10 V;
- NTC (temperature probe only)

##### Step 6/10

Select the type of signal from the limit probe in zone 1. The signals available are those already listed in step 5/10.

##### Step 7/10

Select the type of signal from the main probe or from an external controller to control zone 2. The signals available are those already listed in step 5/10.

##### Step 8/10

Select the type of signal from the limit probe in zone 2. The signals available are those already listed in step 5/10.

Step 9/10

Enter the set points for zone 1 and zone 2 relating to the main probe and limit probe.

Step 10/10

Enter the system date and time.

The wizard is now finished: you can choose whether or not to display it the next time humiFog direct is powered on. In any case, the wizard is always accessible from the settings menu on the graphic terminal.

### 7.3 Touch display

#### HOME menu

The "HOME" menu includes information about the pumping station and the zones, including current production, information on the probes and unit status.

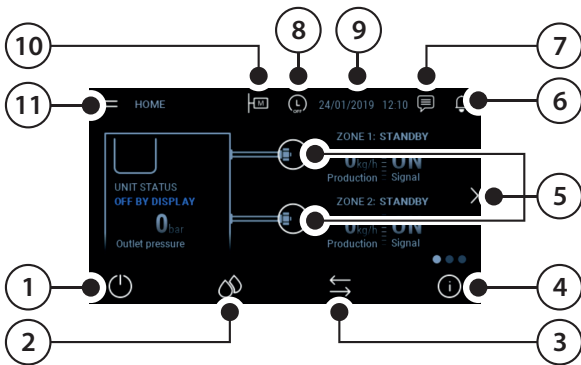

Fig. 7.d

Pos.	Function	Pos.	Function
1	ON/OFF quick menu	7	Notification centre
2	Set point quick menu	8	System date & time
3	Input/output quick menu	9	Scheduler status
4	System information quick menu	10	Main/Secondary Network
5	Descriptive icon of zone status	11	Main menu
6	Alarm list		

Tab. 7.b

#### 7.3.1 ON/OFF quick menu

Pressing the ON/OFF quick menu icon accesses the screen for switching the entire system or individual zones on and off. To switch on or off the unit or zones (ON when the indicator is positioned to the right, OFF when positioned to the left), press the button.

Message	Values	Meaning
Unit	ON	Enables the pump to operate according to zone request
	OFF	Switches the pumping unit OFF
Zone 1/2 (visible only if unit ON)	START	Enables atomisation in zone 1/2 according to the request
	PAUSE	Temporarily stop atomisation in zone 1/2

Tab. 7.a

The menu also contains information on the type of system start-up control signal. To return to the home menu, press the "HOME" icon.

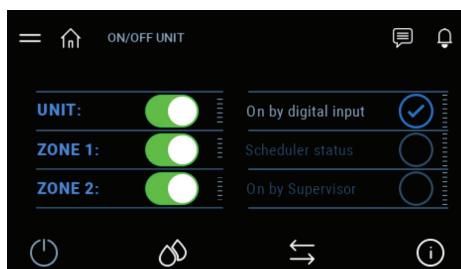

Fig. 7.e

#### 7.3.2 Set point quick menu

Press the icon to access the menu. The menu is used to modify the set point and proportional control band. Press the white number to change the value. Enter the desired value and press the confirm button (✓).

Title	Message	Values	Default
Zone 1 set	Main probe set point	0-100% rH 0-40 °C	50% rH 25 °C
(Zone 2 set)	Main probe band	0-10% rH 0-10 °C	5% rH 2 °C
	Limit probe set point	0-100% rH 0-40 °C	80% rH 15 °C
	Limit probe band	0-10% rH 0-10 °C	5% rH 2 °C

Tab. 7.c

To move from one area to another, or from one page to another, press the right and left arrows on the display and repeat the same operations to change the values.

To return to the home menu, press the "HOME" icon.

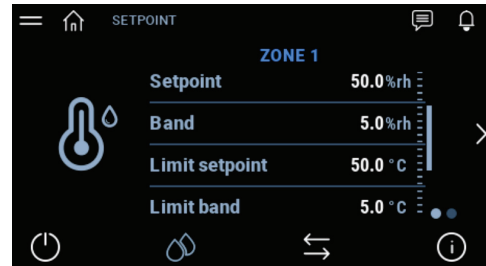

Fig. 7.f

#### 7.3.3 INPUT/OUTPUT quick menu

Press the icon to access the menu.

The input/output dashboard offers an intuitive and real-time view of the system operating status, the values read by the humiFog direct cabinet probes, the status of the mechanical components in the water circuit and the water flow path.

Mechanical component	I/O dashboard symbol	System components
Solenoid valve	(Valve closed) (Valve open)	FV: cabinet fill valve BYP: bypass valve DC: cabinet drain valve FV1: zone 1 fill valve DR1: zone 1 drain valve FV2: zone 2 fill valve DR2: zone 2 drain valve
Pressure sensor		LPS: low pressure sensor RHP: high pressure sensor
Temperature sensor		T: water temperature sensor
Pressure switch		HP: high pressure switch
Pump		Cabinet pump
Nozzles	(Atomise ON) (Atomise OFF)	Zone nozzles

Tab. 7.d

To return to the home menu, press the "HOME" icon.

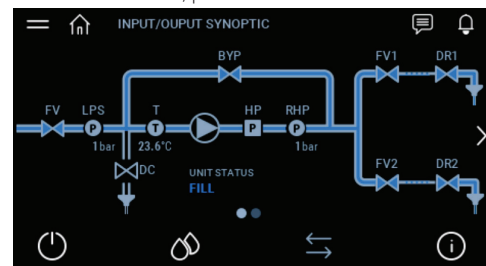

Fig. 7.g

To switch to display the input/output values in table form, press the right arrow.

If using wireless probes, to display the input/output values, press the right arrow again.

Use the slider to scroll through the table.

To return to the previous display, press

To return to the home menu, press the "HOME" icon

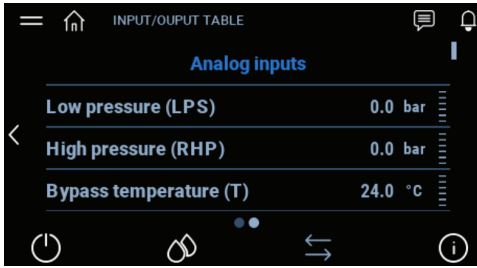

Fig. 7.h

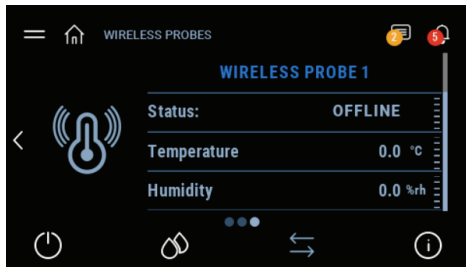

Fig. 7.i

### 7.3.4 INFO quick menu

Press the icon to access the menu.

Menu describing humidifier status, software and hardware information. To move from one page to another, press the arrows on the right and left of the display.

To scroll through the displayed information, press the slider.

To return to the home menu, press the "HOME" icon



Fig. 7.j

### 7.3.5 Zone status

To view more details for the single zone, on the display home page press the white nozzle icon or use the arrows on the right and left of the display to move from one zone to the other.

To return to the home menu, press the "HOME" icon

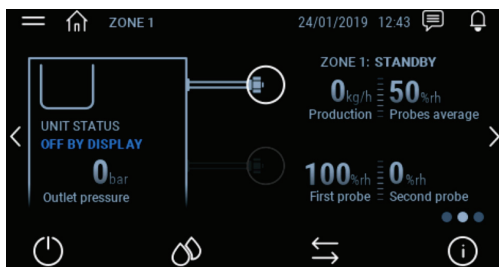

Fig. 7.k

### 7.3.6 Alarm list

Press the icon to display the alarm list.

To view the alarm log, press

To reset the alarms, press

To return to the previous display, press

To return to the home menu, press the "HOME" icon

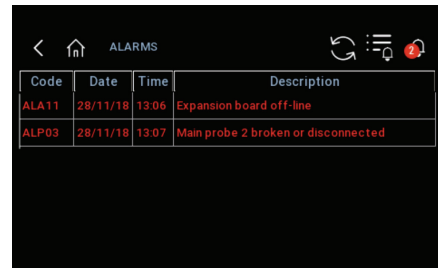

Fig. 7.l

### 7.3.7 Notification centre

Press the icon to access the notification centre.

To view the details of an individual notification, press the notification.

To return to the previous display, press

To return to the home menu, press the "HOME" icon

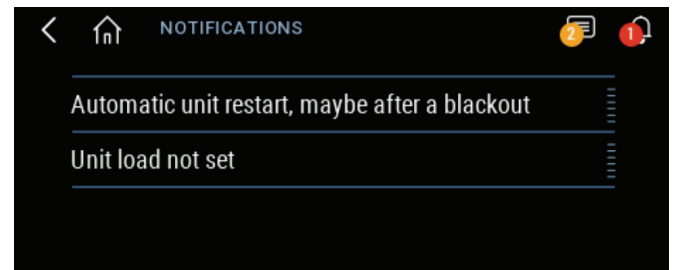

Fig. 7.m

### 7.3.8 System date and time

The system date and time is displayed.

### 7.3.9 Scheduler status

If enabled, the scheduler status (on/off) is shown. Pressing the icon accesses the scheduler section, described in the following paragraph "5.3.16 Scheduler".

### 7.3.10 Main/Secondary Network

Only for single-zone cabinets, if the Main/Secondary network is enabled for several humidifiers, the icon is displayed. For the Main unit, the letter M is displayed, for Secondary units the letter S is displayed. Press the icon to access information from the humidifier network. The page displayed shows some of the characteristics of the individual unit and the system.

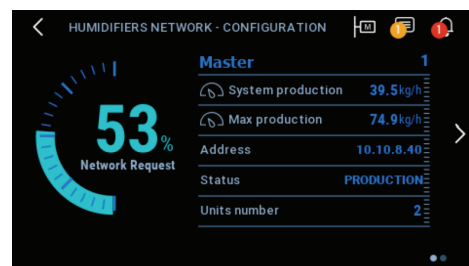

Fig. 7.n

To quickly display the IP addresses of the units making up the Main/Secondary network, press

To view the page with details on current production and the status of the humidifiers in the Main/Secondary network, press the right arrow.

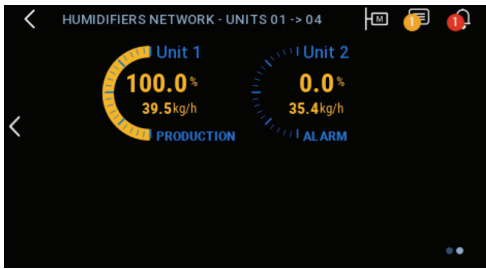

Fig. 7.o

To access information on the individual humidifier, press the desired unit.

**7.3.11 Main menu**

Press the icon to access the main menu. The menu provides access to the system items that are available without entering a password.

To return to the previous display, press

To return to the home menu, press the "HOME" icon

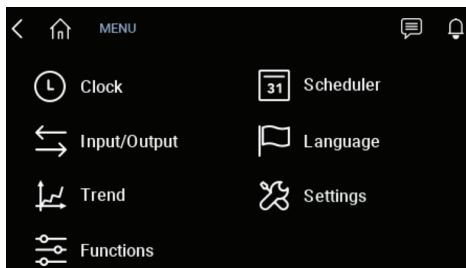

Fig. 7.p

Description of the menus:

Menu	Description
Clock	Date and time setting
Input/Output	Display the analogue and digital inputs/outputs
Graphs	Display historical and real-time operation of the humidifier
Functions	Special and manual functions
Scheduler	Manage scheduling of working time bands
Language	Set the menu language
Settings	Access advanced humidifier configuration (Installer password 77). Menu: E. Settings. Change unit of measure (Imperial/International)

Tab. 7.e

**7.3.12 Clock**

Press the icon to access the function.

Press the text to change the desired parameters.

To return to the previous display, press

To return to the home menu, press the "HOME" icon

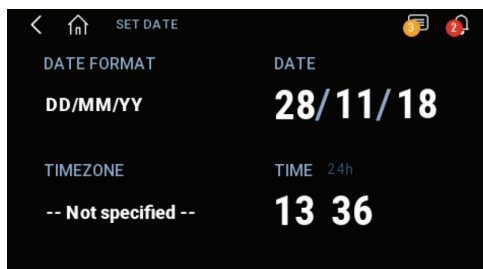

Fig. 7.q

**7.3.13 Input/Output**

Press the icon to access the function.

The same screen is displayed, which is also accessible from the input/output quick menu.

**7.3.14 Graphs**

Press the icon to access the function.

The graphs function is used to view the values of some system analogue and digital variables over a certain time frame.

Press the zone to be viewed.

On the first screen displayed, the real-time value of the analogue and digital variables relating to the zone is plotted. The value of each variable is shown numerically in the table to the right of the graphs.

To scroll through the displayed information, press the slider.

To return to the previous display, press

To return to the home menu, press the "HOME" icon

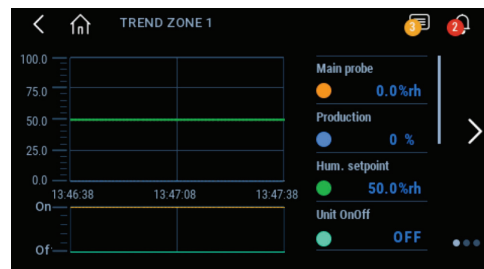

Fig. 7.r

To move from one page to another, press the arrows on the right and left of the display.

Moving to the right, the second screen displays the history of analogue variables for the zone.

Press the icon to save the graph displayed to external memory.

Press the icon to restore the initial view.

Press the icon to select the length of the period to be viewed.

Press the arrows under the graph to change the period displayed.

Press the icon to hide the variables, magnify the graph and move the red cursor. The value of the variables corresponding to the red cursor is shown in the table on the right.

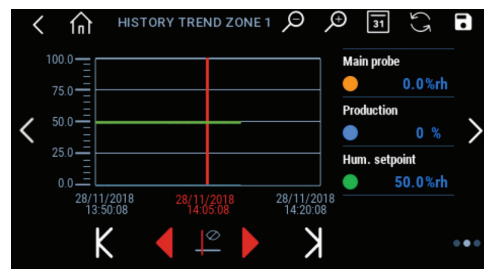

Fig. 7.s

Moving to the right again, the history of the system's digital variables is displayed on the third screen.

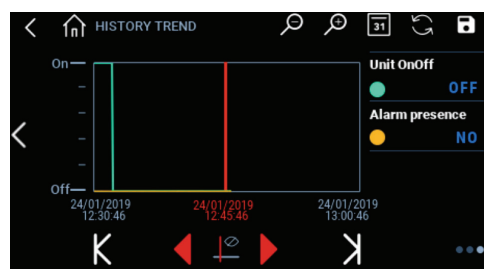

Fig. 7.t

**7.3.15 Functions**

Press the icon to access the functions.  
The option to select the language following a reboot or unit power on can be enabled or disabled.

To return to the previous display, press

To return to the home menu, press the "HOME" icon

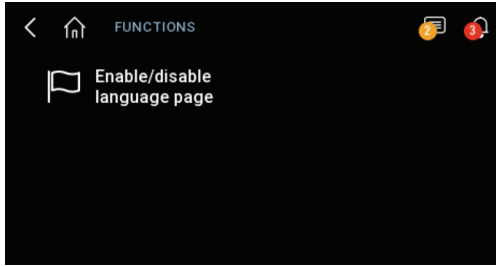

Fig. 7.u

**7.3.16 Scheduler**

Press the icon to access the function.

Press the icon to activate or deactivate the scheduler function

Press the icon to access scheduler programming

To return to the previous display, press

To return to the home menu, press the "HOME" icon

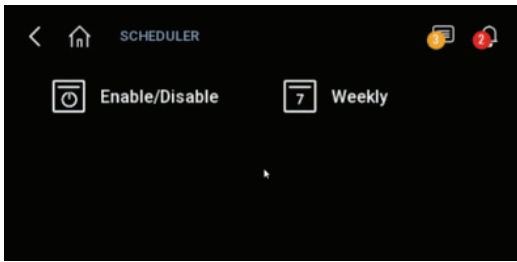

Fig. 7.v

The display shows the weekly scheduling status, press the column with the individual day to access programming

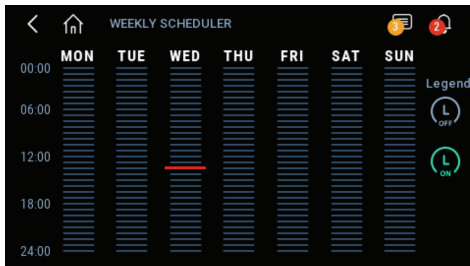

Fig. 7.w

Press the icon to program the scheduler time and status. Use the arrows to move to the previous or next day. Press the icon to copy the scheduler program to the next day.

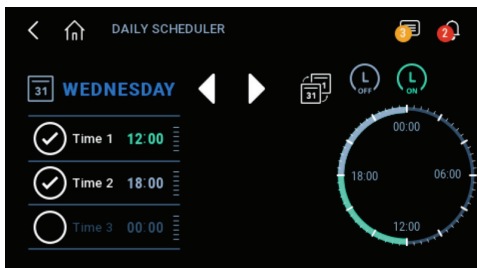

Fig. 7.x

**7.3.17 Language**

Press the icon to access the function.  
Scroll with your finger and select the desired language.

**7.3.18 Settings**

Press the icon to access the function.  
Enter the password (installer password 77) and confirm.  
To return to the previous display, press

To return to the home menu, press the "HOME" icon

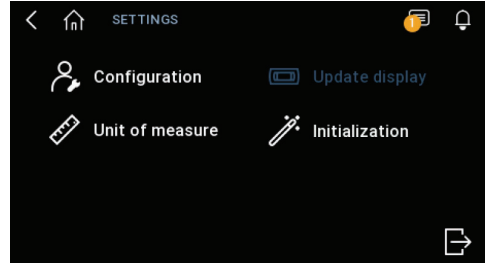

Fig. 7.y

Type in the icon to change the unit of measure.  
Press the icon to update the display application from a USB pendrive  
Press the icon to access the configuration wizard or factory data reset  
Press the icon to access the advanced configuration.  
Press the icon to log out.  
The advanced configuration is managed via a keyboard on the display (fig. 5.a).  
For details on the advanced configuration screens and parameters, see the next chapter.

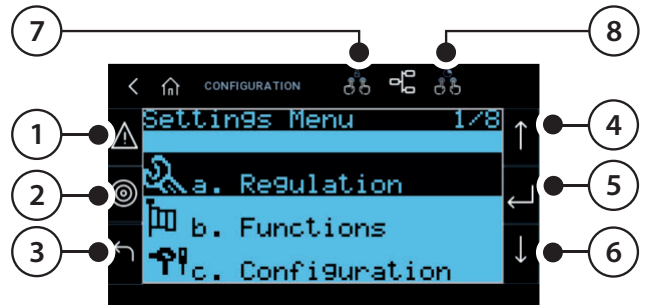

Fig. 7.z

Button	Function
(1)	alarm list and reset any active alarms
(2)	PRG return to the "main" screen
(3)	ESC return to the previous screen/display
(4)	UP access notifications (from main menu only)
(5)	ENTER from the "main" screen: access the INFO screens
(6)	DOWN from the "main" screen: access the INFO screens
(7)	multiple selection of the previous buttons
(8)	multiple selection duration

Tab. 7.f

**7.4 Remote installation of the touch display**

To install the 4.3" touch screen in a remote position, use kit P/N HCTXDA0000. The kit comprises a touch display, a 24 Vdc power supply, a telephone cable and a telephone splitter for simultaneous connection of the two displays (one in the remote position and the other installed on the humidifier).

# 8. ADVANCED CONFIGURATION PARAMETERS AND OPERATING OPTIONS

## 8.1 Main menu and overview of functions

When accessing with password 77, the advanced settings button is available for accessing a series of additional submenus. Each submenu is divided into a number of screens identified by the index shown at the top right on the display. The table below provides a complete overview of the screens.

Menu	Index	Description
a. Control	Da01	Set the type of control in zone 1 and the maximum production
	Da02	Set the type of control in zone 2 and the maximum production
	Da03	<i>(visible if control using two main probes has been enabled)</i> Set the weight of the zone 1 control probes
	Da04	Set the set point and band for the zone 1 main probe
	Da05	Set the set point and band for the zone 1 limit probe
	Da06	<i>(visible if control using two main probes has been enabled)</i> Set the weight of the zone 2 control probes
	Da07	Set the set point and band for the zone 2 main probe
	Da08	Set the set point and band for the zone 2 limit probe
	Da09	Maintenance hour meter, next maintenance, maintenance notice setting
	Da10	Option to reset oil change hour meter, date and time of last reset
	Da11	Unit hour counter (not resettable)
	Da12	Pump or control changeover setting with pump and unit hours setting
b. Functions	Db01	Enable filling and set the filling time
	Db02	Set washing cycle duration and frequency
	Db03	Enable management of the external water treatment system
	Db04	Management of advance start and delayed stop of blower fans
	Db05	Export event log via USB
	Db06	Export alarm log via USB
c. Configurations	Dc01	Set the type of signal for the main humidity probe in zone 1, minimum/maximum probe reading, probe offset, enable disconnected probe alarm and set the alarm delay
	Dc02	Set the type of signal for the main temperature probe in zone 1, minimum/maximum probe reading, probe offset, enable disconnected probe alarm and set the alarm delay
	Dc03	Set the type of external signal for zone 1, minimum/maximum signal value, signal offset
	Dc04	Set the NO/NC logic for the external on/off contact (humidistat)
	Dc05	Set the type of signal for the humidity limit probe in zone 1, minimum/maximum probe reading, probe offset, enable disconnected probe alarm and set the alarm delay
	Dc06	Set the type of signal for the temperature limit probe in zone 1, minimum/maximum probe reading, probe offset, enable disconnected probe alarm and set the alarm delay
	Dc07	Set the type of signal for the main humidity probe in zone 2, minimum/maximum probe reading, probe offset, enable disconnected probe alarm and set the alarm delay
	Dc08	Set the type of signal for the main temperature probe in zone 2, minimum/maximum probe reading, probe offset, enable disconnected probe alarm and set the alarm delay
	Dc09	Set the type of external signal for zone 2, minimum/maximum signal value, signal offset
	Dc10	Set the NO/NC logic for the external on/off contact (humidistat)
	Dc11	Set the type of signal for the humidity limit probe in zone 2, minimum/maximum probe reading, probe offset, enable disconnected probe alarm and set the alarm delay
	Dc12	Set the type of signal for the temperature limit probe in zone 2, minimum/maximum probe reading, probe offset, enable disconnected probe alarm and set the alarm delay
	Dc13	<i>(visible for single-zone cabinet)</i> Set wireless probes 1-4: main, limit or absent
	Dc14	<i>(visible for single-zone cabinet)</i> Set wireless probes 5-8: main, limit or absent
	Dc15	<i>(visible for two-zone cabinet)</i> Enable wireless probes 1-4 for the main/limit control function in zone 1/2
	Dc16	<i>(visible for two-zone cabinet)</i> Enable wireless probes 5-8 for main/limit control function in zone 1/2
	Dc17	Set the percentage weight of the wireless probes
	Dc18	Set humidification load in zone 1/2
Dc19	Setting the zone 1 pressure relief time	
Dc20	Setting the zone 2 pressure relief time	
Dc21	<i>(visible for two-zone cabinet)</i> Set the system anti-drip time	
Dc22	Set the anti-pressure return time	
Dc23	Set the cabinet pressure probe offsets	
d. Network unit	Dd01	Enable the humidifier network using the PRG button (if enabled, the network symbol appears on the main screen)
	Dd02	Set the IP address of cabinet 1/2/3/4 in the network and check status, online/offline
	Dd03	Set maximum load and grouped/balanced distribution set point
	Dd04	Set cabinet rotation time (0 h = rotation disabled)
	Dd05	Unit offline alarm timeout
	Dd06	Disable network settings for the current unit (if Y, the network symbol is not shown on the main screen)
	Dd07	Current unit production request
	Dd08	Check status and production % of unit 1/2/3/4 on the network
e. Manual mode	De01	Enable manual zone request, set request % and enable management of individual c.phc outputs to check operation of electro-mechanical components
	De02	Manual management of contactor, fill valve FV, cabinet drain valve DR, bypass valve BYP
e. Manual mode	De03	Manual management of zone 1 fill valve FV1, zone 1 drain valve DR1, zone 1 fans, set zone 1 production %
	De04	Manual management of zone 2 fill valve FV2, zone 2 drain valve DR2, zone 2 fans, set zone 2 production %
	De05	Manual management of unit status contact, alarm relay, cabinet fan, WTS contact
f. Initialisation	Df01	Access to the configuration wizard
	Df02	Setting the screen language
	Df03	Change menu access password
	Df04	Setting the international/imperial measuring system
	Df05	Setting the machine model
	Df06	Restore factory values
	Df07	Enabling of USB port reading for unit software updating

Menu	Index	Description
g. Supervision	Dg01	(visible for single-zone cabinet) Set the serial address, enable unit on/off and control from supervisor
	Dg02	(visible for two-zone cabinet) Set the serial address, enable unit on/off and control from supervisor
	Dg03	Select supervisor protocol
	Dg04	BMS supervisor port configuration: baud rate, stop bits, parity
	Dg05	Ethernet supervisor port configuration: DHCP, IP address, mask, gateway, DNS. Important - these values must be provided by the local network administrator
	Dg06	BACnet configuration: address, maximum number of Mains, maximum number of frames
	Dg07	Device instance parameter for BACnet configuration
h. Logout		Exit the settings menu: request password on next access

Tab. 8.a

## 8.2 Control

### 8.2.1 Modulation of production

The system modulates the atomisation of water intermittently, in PWM mode (pulse width modulation). Within a time period of 120 seconds (settable value), the unit will deliver pressurised water to the blower units for atomisation by the nozzles in the room:

- for 120 seconds continuously, when there is maximum production request;
- for a fraction of time  $T_{on}$  less than 120 seconds (minimum 8% of the entire period) and proportional to the request signal, if not at the maximum.

When atomisation stops, the pump remains active and the water is recirculated through an internal bypass circuit in the pumping unit, rather than being delivered to the blower units.

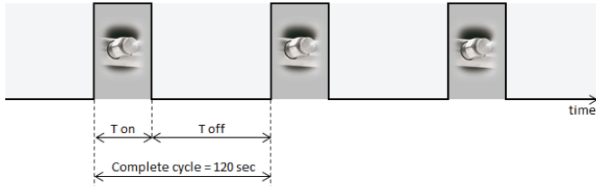

Fig. 8.r

The type of control is set on the following screen:

Index	Description	Parameter
D301	Type of control	Set the type of control
D302	control	Default: humidity (one probe) Options: proportional to external signal, proportional to external signal with limit probe, On/Off signal, humidity (one probe), temperature (one probe), humidity with limit, temperature with limit, humidity (two probes), temperature (two probes)

Tab. 8.b

### 8.2.2 Proportional control to an external signal (modulating operation)

Atomisation is proportional to the value of an external signal Y, (selectable from the following options: 0 to 1 Vdc; 0 to 10 Vdc; 2 to 10 Vdc; 0 to 20 mA; 4 to 20 mA). The maximum production  $P_{max}$  corresponds to the maximum value of the external signal Y, and will be the humidifier's rated production. The activation hysteresis  $hy$  is not settable by the user.

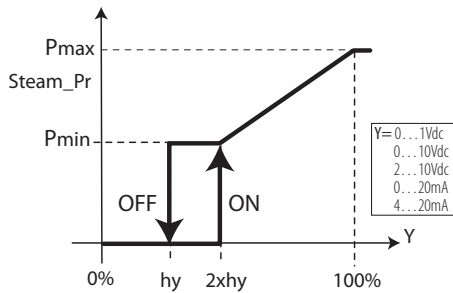

Fig. 8.s

Key:

Water_pr	Pressurised water production	Y	External signal
$P_{max}$	Max production	$hy$	Activation hysteresis
$P_{min}$	Min production		

### 8.2.3 Autonomous control with humidity or temperature probes

When using a main humidity control probe and an optional limit humidity probe, atomisation is related to the % rH reading made by the relative humidity probe and increases as the value read deviates from the set point  $St$ . Maximum production  $P_{max}$  corresponds to the case where the humidity value, read by the probe, is BP away (proportional band) from the set point. The activation hysteresis  $hy$  is not settable by the user.

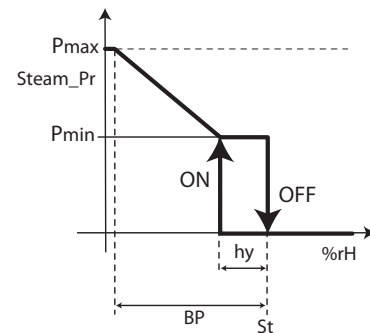

Fig. 8.t

Key:

Water_pr	Pressurised water production	Y	Humidity measurement
$P_{max}$	Max production	$hy$	Activation hysteresis
$P_{min}$	Min production	$St$	Humidity Set point

When using a main temperature control probe and an optional limit temperature probe, atomisation is related to the temperature reading in °C or °F made by the probe and increases as the value read deviates from the set point  $St$ . Maximum production  $P_{max}$  corresponds to the case where the temperature value, read by the probe, is BP away (proportional band) from the set point. The activation hysteresis  $hy$  is not settable by the user.

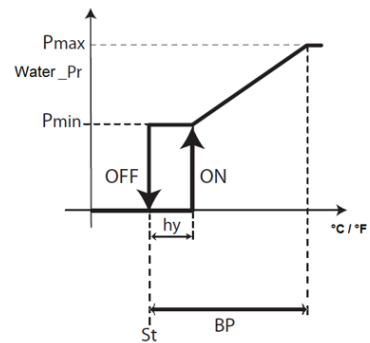

Fig. 8.u

Key:

Water_pr	Pressurised water production	T	Temperature measurement
$P_{max}$	Max production	$hy$	Activation hysteresis
$P_{min}$	Min production	$St$	Temperature Set point

For "humidity (one probe)" or "temperature (one probe)" control, one single main probe can be connected and configured, either wired or wireless.

For "humidity with limit" or "temperature with limit" control, a wired probe can be connected as the main probe and a wired probe as the limit. If using wireless probes (maximum of four), two groups of probes can be defined: the group of main probes and the group of limit probes. In this case, the

average will be calculated between the main probes, depending on the defined weight, and the limit probes will also have their own average, again depending on the defined weight. For "humidity (two probes)" or "temperature (two probes)" control, only a group of main probes can be defined. Wired probes can be connected to the main probe input (M2.1) and the limit probe input (M2.5), which will be used as a second probe, with the average calculated. If using wireless probes (maximum of four), only a group of main probes can be defined, with the average calculated, depending on the defined weight. For the connections of the signals and/or probes, see chap. 4.

**8.2.4 Weighted average of the probes (installer menu)**

If using two temperature probes or two humidity probes, the humidifier controller will calculate the weighted average of the probe readings. In this way, two probes can be used, for example humidity probes, at opposite ends of the room, calculating the average.

Index	Description	Parameter
Dc03	Weight of the probes	Set the weight of the probes
Dc06		Default: 100 Possible settings: 0 to 100 Step: 1

The weight of each probe should be expressed with a value from 0 to 100.

The weighted average is calculated as follows:

$$\text{Weighted average} = \frac{(S1 \times p1) + (S2 \times p2)}{p1 + p2}$$

where "Si" is the probe reading, and "pi" the relative weight.

To calculate the arithmetic average, equal weights should be set (for example: p1 = p2 = 100).

**8.3 Functions**

**8.3.1 Filling**

For correct functioning of the system there must be no air in the lines, so as to avoid vibrations, unstable pressure and poor quality atomisation. To eliminate all air, the filling time must be set correctly. When starting the system the first time, measure the time required for the water to reach the end of the circuit, and wait only until water visibly comes out of the circuit. The longer the water circuit, the higher the filling time needs to be.

With reference to the high pressure hose supplied (Øint=6.3 mm), it is recommended to set the times indicated in the table.

Pumping station	40/50 l/h	80/90 l/h
Time	1 min per 15 m of tubing	1 min per 30 m of tubing

Ref.	Display	Description	Range	Def	UoM
Db01	En. filling	When the pumping station needs to start and the water supply line is detected as being empty, i.e. when first starting, enabling the pump, starting again for the new season etc., by setting the parameter to Yes, the pump delivers the flow-rate for the time defined by the following parameter, so as to fill the line before atomisation commences	Yes/No	Yes	
	Duration	Line filling time before starting atomisation, only if the water supply line is detected as being empty	1/60	2	min

Tab. 8.c

**8.3.2 Washing**

The washing function involves flushing all of the water pipes for a set time. The purpose is to completely wash the system and avoid stagnation.

Ref.	Display	Description	Range	Def	UoM
Db02	Washing: periodical daily	washing carried out after a set number of hours of inactivity.	periodical daily disabled	peri-odical	
	Disable washing	Washing performed daily at a predefined time Washing disabled			
	Interval Time	Number of hours of inactivity after which a periodical washing cycle is performed Time of day when the daily washing cycle is performed	0/99 0/24	12 0	h h
	Duration	Periodical washing cycle time in minutes Daily washing cycle time in minutes	0/60 0/60	4	min

Tab. 8.d

NOTICE: (\*) it is advisable to set a washing time twice as long as the filling time.

**8.3.3 Blower fan management**

The blower fans that atomise the water can be started before atomisation commences, so as to reach an air flow that can support atomisation when this starts.

A delay can be set for stopping the fans when atomisation ends, so as to guarantee air flow immediately after the end of atomisation.

Ref.	Display	Description	Range	Def	UoM
Db04	On advance	Start fans in advance before starting atomisation	0-10	3	s
	Off delay	Delay in stopping fans after atomisation ends	3-120	10	s

Tab. 8.e

**8.4 Configurations**

**8.4.1 Main humidity probe setting**

The main probe can be configured on screen index Dc01 for the single-zone and Dc07 for two-zone cabinets.

Index	Description	Parameter
Dc01	Main probe	Main probe configuration
Dc07		Default: Enable: Enabled (depending on the type of control) Type: 0-10 V Minimum: 0% rH - Maximum: 100% rH Offset: 0 En. Al (enable alarms): Yes Del: 60 seconds Possible settings: Type 0-10 V/0-1 V/NTC/4-20 mA/0-20 mA/2-10 V Minimum: 0-100% rH - Maximum: 0-100% rH Offset: 0 En. Al (enable alarms): Yes Del: 0-600 seconds

Tab. 8.f

For each probe, after having specified the type, the minimum and maximum values readable can be defined, as well as an "offset" to compensate for any imprecisions in the value read (example: offset = 3% rH corresponds to a 3 percent increase in the humidity value read by the probe). The "En. Al." parameter enables the alarms corresponding to probe faults. If a fault is detected for longer than the value of the "Delay" parameter (seconds), the "main probe broken or disconnected" alarm will be activated.

### 8.4.2 Main temperature probe setting

The main probe can be configured on screen index Dc02 for the single-zone and Dc08 for two-zone cabinets.

Index	Description	Parameter
Dc02 Dc08	Main probe	Main probe configuration Default: Enable: Enabled (depending on the type of control) Type: 0-10 V Minimum: 0°C - Maximum: 60°C Offset: 0 En. Al (enable alarms): Yes Del: 60 seconds Possible settings: Type 0-10 V/0-1 V/NTC/4-20 mA/0-20 mA/2-10 V Minimum: 0-60°C - Maximum: 0-100°C Offset: 0 En. Al (enable alarms): Yes Del: 0-600 seconds

Tab. 8.g

For each probe, after having specified the type, the minimum and maximum values readable can be defined, as well as an "offset" to compensate for any imprecisions in the value read (example: offset = 3% rH corresponds to a 3 percent increase in the humidity value read by the probe). The "En. Al." parameter enables the alarms corresponding to probe faults. If a fault is detected for longer than the value of the "Delay" parameter (seconds), the "main probe broken or disconnected" alarm will be activated.

### 8.4.3 External signal setting

The type of external signal can be configured on screen index Dc03 for the single-zone and Dc09 for two-zone cabinets.

Index	Description	Parameter
Dc03 Dc09	Main probe	Main probe configuration Default: Enable: Enabled (depending on the type of control) Type: 0-10 V Minimum: 0 - Maximum: 100 Offset: 0 En. Al (enable alarms): Yes Del: 60 seconds Possible settings: Type 0-10 V/0-1 V/4-20 mA/0-20 mA/2-10 V Minimum: 0-100 - Maximum: 0-100 Offset: 0 En. Al (enable alarms): Yes Del: 0-600 seconds

Tab. 8.h

### 8.4.4 Humidity limit probe setting

The limit probe can be configured on screen index Dc05 for the single-zone and Dc11 for two-zone cabinets.

Index	Description	Parameter
Dc05 Dc11	Main probe	Main probe configuration Default: Enable: Enabled (depending on the type of control) Type: 0-10 V Minimum: 0% rH - Maximum: 100% rH Offset: 0 En. Al (enable alarms): Yes Del: 60 seconds Possible settings: Type 0-10 V/0-1 V/NTC/4-20 mA/0-20 mA/2-10 V Minimum: 0-100% rH - Maximum: 0-100% rH Offset: 0 En. Al (enable alarms): Yes Del: 0-999 seconds

Tab. 8.i

For each probe, after having specified the type, the minimum and maximum values readable can be defined, as well as an "offset" to compensate for any imprecisions in the value read (example: offset = 3% rH corresponds to a 3 percent increase in the humidity value read by the probe). The "En. Al." parameter enables the alarms corresponding to probe faults. If a fault is detected for longer than the value of the "Delay" parameter (seconds), the "main probe broken or disconnected" alarm will be activated.

### 8.4.5 Temperature limit probe setting

The limit probe can be configured on screen index Dc06 for the single-zone and Dc12 for two-zone cabinets.

Index	Description	Parameter
Dc06 Dc12	Main probe	Main probe configuration Default: Enable: Enabled (depending on the type of control) Type: 0-10 V Minimum: 0°C - Maximum: 60°C Offset: 0 En. Al (enable alarms): Yes Del: 60 seconds Possible settings: Type 0-10 V/0-1 V/NTC/4-20 mA/0-20 mA/2-10 V Minimum: 0-60°C - Maximum: 0-100°C Offset: 0 En. Al (enable alarms): Yes Del: 0-600 seconds

Tab. 8.j

For each probe, after having specified the type, the minimum and maximum values readable can be defined, as well as an "offset" to compensate for any imprecisions in the value read (example: offset = 3% rH corresponds to a 3 percent increase in the humidity value read by the probe). The "En. Al." parameter enables the alarms corresponding to probe faults. If a fault is detected for longer than the value of the "Delay" parameter (seconds), the "main probe broken or disconnected" alarm will be activated.

### 8.4.6 Pressure relief time setting

In the event of poor atomisation quality or dripping in the final atomisation phase after a modulation period (Ton), the pressure relief time can be adjusted, increasing it as much as necessary. The required delay increases according to the length of the high pressure water line. Increasing this time may mean the anti-dripping time also needs to be adjusted, for two-zone systems. Always check correct operation of the atomisation on and off phases in PWM modulation mode.

Ref.	Display	Description	Range	Def.	UoM
Dc19	Pressure relief	Line pressure dissipation	0-30	5	s
Dc20	time	when atomisation off			

Tab. 8.k

### 8.4.7 Anti-dripping time setting

For two-zone cabinets poor atomisation quality in the initial atomisation phase after a modulation period (Toff), the anti-dripping time can be adjusted, increasing it as much as necessary. The required delay increases according to the length of the high pressure water line and the setting of the pressure relief parameter.

Ref.	Display	Description	Range	Def.	UoM
Dc21	Anti-dripping time	Fill line when starting atomisation	0-30	0	s

Tab. 8.l

### 8.4.8 Anti-pressure return time setting

In the event of alarm ABA05: high bypass pressure, slightly increase the anti-pressure return time to allow better pressure dissipation in the cabinet.

Ref.	Display	Description	Range	Def.	UoM
Dc22	Anti-pressure return	Dissipation of cabinet pressure	0.2-30	1.7	s

Tab. 8.m

## 9. MAIN/SECONDARY NETWORK OF HUMIDIFIERS

### 9.1 Description of the Main/Secondary system

To extend humidification capacity in an individual zone, several humidifiers can be connected together in a Main/Secondary system. For example, if humidification request is 160 kg/h, a Main/Secondary system can be created with two 80 kg/h humiFog direct single-zone unit. A maximum of 3 Secondary units can be connected to a Main, meaning a total of 4 humidifiers in the same system. The Main and Secondary units are connected using a local Ethernet network, and in the case of just two units (one Main and Secondary) involves a direct connection between the two unit controllers via Ethernet RJ45 Category 5 cable.

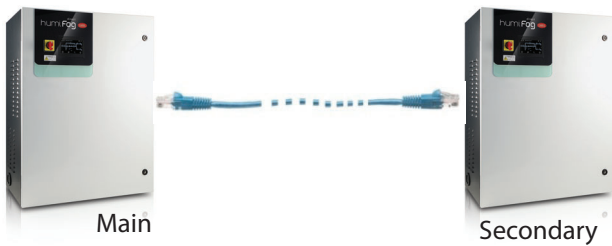

Fig. 9.a

If the Main/Secondary system comprises three or more units (maximum 4), a network switch is required.

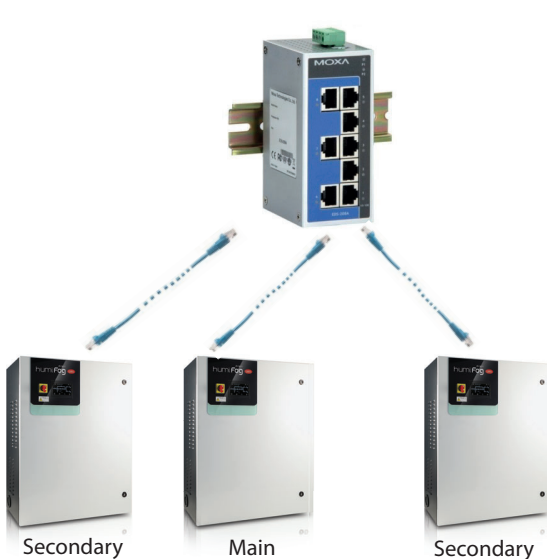

Fig. 9.b

The Ethernet port is available on the humidifier's c.pHC controller:

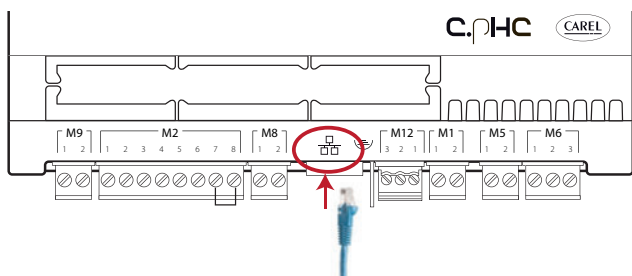

Fig. 9.c

**Note:** use Ethernet CAT-5 STP cable, maximum length 100 m. To connect the shield, use the earth connector provided on the controller.

### 9.2 Network switch for Main/Secondary connection

The Main/Secondary connection of more than two units requires the use of an industrial grade switch. Carel markets a switch (P/N: KITSE08000) that can connect a maximum of eight units (8 Ethernet ports). If necessary, use several KITSE08000 switches with a cascaded arrangement.

Main technical specifications of the KITSE08000 switch:

Number of ports	8
Installation	DIN rail
Operating temperature	-10 to 60 °C (14-140 °F)
Power supply	12/24/48 VDC
	18-30 VAC (47-63 Hz)
Current @24 VDC	0.13 A
Protection	IP30

Tab. 9.a

### 9.3 Type of Main/Secondary system installation

The Main/Secondary system features one main unit (Main), which manages operation of the secondary units (Secondaries). The external signal or probe connections, depending on the set control type, are made to just one of the humidifiers in the system. The unit that the signal is connected to will automatically be identified as the Main. Consequently, the Main does not need to be especially configured..



While the Main unit is powered on, the system will be able to operate even in the event of malfunctions on the Main (alarms, stopped production,...), as the unit's controller will send all the required data to the Secondaries. Obviously, unless redundancy has been factored into the total humidification capacity, this case will be lower than requirements. If the Main is switched off completely, the Main/Secondary system will not be able to read the control/probe signals. Consequently, it is suggested to connect all the humidifiers in the system (or at least two units) to the external signal or fit them with independent probes.

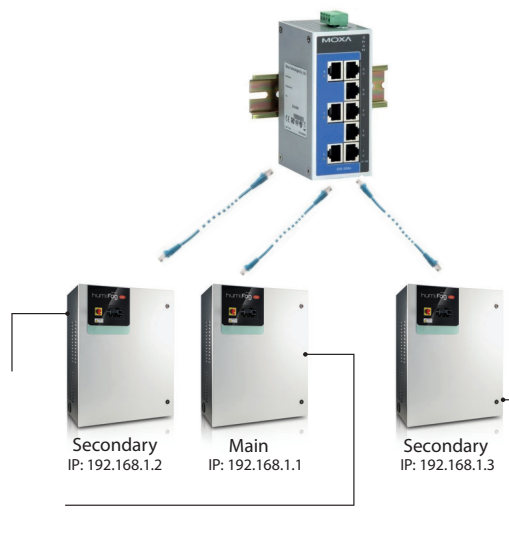

Fig. 9.d

Systems set up in this way will be able to cover the humidification requirement. In this specific case, the Main will always be the unit with the lowest IP address of those connected to the signal/probes. If necessary, an additional humidifier (backup) can be installed to cover request in the event of malfunctions on one of the units in the system.

## 9.4 Main/Secondary system configuration

To configure the Main/Secondary system, proceed as follows:

1. Connect the probes or the external signal to the unit and complete the configuration (control type, type of signal, maximum production ...);
2. Set the IP addresses of the individual units so that they belong to the same subnetwork (subnet mask); the screen index for this configuration is Dh05 (D. Settings – g. Supervision). The IP address is set on the display on each unit, assigning a different address to each unit in the same subnetwork. If necessary, contact the local network administrator. Remember that the default address for each unit is 192.168.0.1, and the default subnet mask is 255.255.255.0. For further details see paragraph 8.1.1 "IP address and network configuration"
3. Connect the units making up the Main/Secondary system to the local Ethernet network via a switch. If using just two units, an RJ45 category 5 cable can be used, connected directly to the Ethernet ports on the two c.pHC controllers.
4. Configure the Main/Secondary system by enabling the units one at a time (this operation can be performed on the display on any of the units):
  - 4.1 Display screen index Dd01 and then access configuration mode by pressing "PRG".
  - 4.2 Enter the IP address for "Unit 1" and confirm by pressing "ENTER".
  - 4.3 Repeat the operations described above (4.1 and 4.2) for all the other units in the Main/Secondary system.
 (The units will join the Main/Secondary system (online) immediately after being added to the network.)

**Note:** the Main unit will always (automatically) be the one with the lowest IP address out of the units connected to the probes or external signal.

**Note:** it may take a few seconds (max 10 s) for the Main to start sending the production request to the Secondary/Secondaries. This is also true when, automatically, the Main unit is changed (for example, in the event of malfunctions).

### 9.4.1 Maximum Main/Secondary system production

In the same way as for the individual unit configuration, for the Main/Secondary system the maximum capacity can also be set. To set the maximum capacity, go to menu Dd03. The "Capacity" parameter identifies the maximum production request for the Main/Secondary system, and can therefore be set by the user.

The "Maximum capacity" parameter (read-only), on the other hand, indicates the sum of the sizes of each unit added to the system; this value is therefore the maximum effectively available to the Main/Secondary system. Consequently, "Capacity" will always be  $\leq$  "Maximum capacity".

In any case, the maximum production can be defined for each individual unit in the system by limiting production from its maximum according to the size. In this case, "Maximum capacity" will be updated keeping in consideration these reductions.

### 9.4.2 Unit production distribution logic in the Main/Secondary system

The activation logic of the units in the Main/Secondary system can be set, choosing between "Grouped" or "Balanced", on screen Dd03.

#### Grouped distribution

- the units are activated in series, one after the other, according to the request.

**Example:** M/S system comprising two 80 kg/h units, for a maximum total capacity of 160 kg/h. While the request remains below 50% (80 kg/h) only one unit will be activated (for example, Unit 1), as soon as the request exceeds the 50%, the second unit will also be activated (in the example, Unit 2).

#### Balanced distribution:

- the units are activated in parallel at the same time, splitting the total production request between the number of units in the M/S system.

**Example:** M/S system comprising two 80 kg/h units, for a maximum total capacity of 160 kg/h. If the request is 50%, both Unit 1 and Unit 2 will be activated at 50% of production (40 kg/h + 40 kg/h = 80 kg/h). If the request is 90% (144 kg/h), both Unit 1 and Unit 2 will be activated at 90% (72 kg/h + 72 kg/h = 144 kg/h).

For Grouped Distribution only, if the request does not require the use of all the units, the automatic rotation function can ensure that the individual units total the same number of operating hours. To enable and configure the operating hours for unit rotation, set the "auto-rotation time" parameter on screen Dd04.

**Note:** if the "auto-rotation time" parameter is = 0, the auto-rotation function is disabled.





### 9.4.3 Disconnect unit from the Main/Secondary system

To remove a unit from the Main/Secondary system, thus reducing the number of units available in the system, use the "Disconnect unit" function on screen Dd06. This can be done on any of the humidifiers in the system.

**Note:** once the unit has been disconnected, this will no longer be visible in the Main/Secondary system, as its IP address will be removed from the list. If a unit is disconnected erroneously, the system can be restored on screen Dd01 (entering its IP). This must be done from the display on a unit that is already connected to the system.

**9.4.4 Display Main/Secondary system**

To display a summary of the Main/Secondary system, go to screen Dd08. The menu displays all the units (01, 02, ...), the status of each unit and current production as a percentage. The following table lists the Main/Secondary network unit status indications:

Symbol	Unit status in the Main/Secondary system
	Indicates the current unit being displayed (PGD or web server)
	The unit is: online
	The unit is: offline
	Unit not configured and not included in the Main/Secondary system

The units in the Main/Secondary system can also be selected one by one, displaying maximum production, unit status, operating hours, current production request and any alarms.

To enter this display, from screen Dd08, select the desired unit and press



, thus accessing screen Dd09. Scroll using the UP/DOWN buttons to display the details of all the units.

**9.4.5 Software backup function in the Main/Secondary system**

Main/Secondary mode can also be used to manage the software backup function; if one or more units in the Main/Secondary system is affected by a malfunction, the system automatically restores humidity production by activating the backup units. The lost production in relation to the humidification request is thus compensated by increasing production on the individual units (where possible) and/or starting any units in standby.

Even if not strictly necessary, to ensure the backup function, the external control signal must be sent to all the units in the Main/Secondary system; if using probes on the other hand, each unit must be fitted with a probe. Only in this way can complete operation be guaranteed in the event of malfunctions.

 **Note:** if a unit goes offline due to a malfunction or shutdown, it will temporarily be excluded from the system, and when next restarted it may take 15 seconds or more to automatically come online status again.

# 10. CONNECTIVITY

## 10.1 Webservice

The web server is a very interesting function when the user has a local network available that humiFog Direct can be connected to. The physical local network connection uses the Ethernet port with RJ45 connector on the humidifier controller (see par. Serial or Ethernet communication) and a normal Ethernet cable (category 5). The integrated web server on the humiFog Direct c.pHC controller is used to configure and monitor the main unit parameters directly from a PC, tablet or smartphone. By opening an internet browser, the humidifier can be accessed from the local network via the humiFog Direct unit's IP address.

### 10.1.1 IP address and network configuration

An IP address is a numerical code that identifies the modem, computer, smartphone or any other device connected to a network, so as that these can communicate with one another. Typically the IP address of multiple devices connected to the same network is identical, except for a few numbers.

EXAMPLE:

- 192.168.1.1 device #1 connected to the network
- 192.168.1.2 device #2 connected to the same network
- 192.168.2.25 device #3 connected to the same network

Remember that when wanting to connect several devices to the same network, a switch is required (this can be supplied by Carel, P/N KITSE08000).

The IP address of the humiFog Direct unit is shown on the display, under:

- D. Settings
- d. Unit networks
- g. Supervisor

Dg05. Ethernet supervision port configuration: DHCP and IP address



Fig. 10.a

To access the web server, to open an internet browser and enter the IP address, followed by /commissioning/index.html (in this case type 10.10.10.176/commissioning/index.html in the browser's address bar).

IP addresses may be :

- dynamic (if using the DHCP function that automatically assigns an IP address when a device is connected)
- static (if there is no DHCP function or it cannot be used, with manual assignment of the IP address directly by the user).

If using a dynamic IP address via the DHCP function on the server, DHCP needs to be enabled on screen Dg05 on the humiFog Direct unit. The IP address shown on the screen will be assigned automatically. The advantage of this feature is that the server and humiFog Direct communicate directly, and there is no need to configure the network parameters (subnet mask and gateway). The disadvantage is that if adding other devices to the same network with humiFog Direct off and not connected, the IP address originally assigned to the unit may change, and therefore the new address needs to be set on screen Dg04 and copied into the browser's address bar.

With a static IP address (with DHCP OFF as by default), on screen Dg05 enter the network parameters manually, as provided by the local network installer. Usually subnet mask and gateway have predefined values (which must be known), while the IP address can be assigned sequentially in relation to another device connected to the same network.

The default network configurations for the c.pHC are:

- unit IP address: 192.168.0.1
- subnet mask: 255.255.255.0
- gateway: 192.168.0.1

**Important:** in the "capacity extension" function (described in paragraph 6.2.2), DHCP cannot be activated, otherwise the units would not be able to communicate together. DHCP must be disabled on screen Dg05 (as by default).

**Important:** the controller is not accessible directly via the internet as a firewall guarantees remote access only over a secure connection (Carel tERA cloud connection). Consequently, outside of the local network the controller cannot be accessed, even if the network administrator assigns a public address.

### 10.1.2 Webservice functions

Once having accessed the webservice, to log in and access the various menu items, use the credentials listed in Table 8.a, according to the type of user.

ID	PW
Service	77
User	44

Tab. 10.a

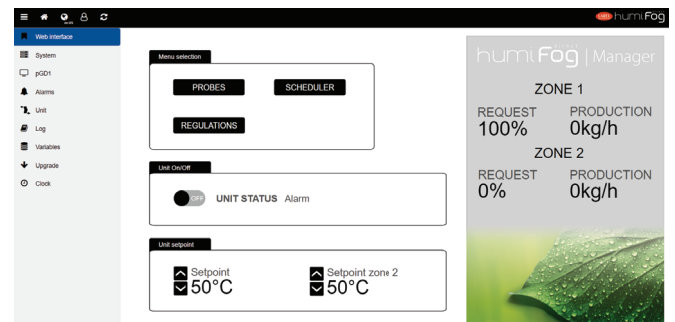

Fig. 10.b

#### Web interface

Once having logged in, the webservice "HOME" page is displayed, also called the web interface. This page displays the main information on the unit, including:

- unit status
- zone request and production
- set point: the value can be set for each zone via webservice
- probes: information on the probe readings and configuration of the main and limit probe. Select the type of signal and define the minimum and maximum values
- scheduler: enable and set the daily and weekly time bands.
- control: select the type of control, set point, differential and minimum/maximum settings

#### System

The system page shows the main information on the application, the available memory, network and system settings. There is also information for registering the unit on the tERA remote cloud service.

#### pGD1

The pGD1 page opens a keyboard for advanced configuration of the unit.

#### Alarms

Display active alarms and alarm log.

#### Unit

Display the values of the digital and analogue inputs and outputs on the unit.

**Log**

The Log page is used to generate graphs of the selected variables, based on the logged data, and export these in .csv format.

**Variables**

Displays all of the variables logged by the unit.  
The variables are available grouped into predefined categories, all of which are active by default.

**Upgrade**

Page reserved for remote software upgrades.

**Clock**

Display and set the unit clock

**Important:** to avoid unwanted modifications, some of the main operating and unit parameters can only be set on the web server when the unit is off (off from keypad, settable on the web server).

**10.2 Supervisor connection**

The supervisor connection uses the serial or Ethernet port (as described on par. 4.6). The default communication settings are Modbus on serial port and BACnet on Ethernet port.

If connecting to the serial port, enable the chosen protocol (Modbus or BACnet) on the screens. For Modbus protocol only, set the baud rate/stop bits/parity. The default values (baud rate: 19000 / 2 stop bits / no parity) should work in almost all cases, unless otherwise specified by the supervisor network installer.

If connecting via Ethernet, follow the procedure (described in paragraph "IP address and network configuration") to look up the unit's IP address, then establish whether the communication protocol will be BACnet and/or Modbus.

**Important:** if using BACnet protocol on a serial port, it cannot be used on the Ethernet port (and vice-versa). The Modbus protocol can on the other hand be used at the same time on both ports.

For all other information, see the manual for the supervisor used and/or contact the supervisor network manager.

**10.3 List of Modbus parameters**

Type	Section	Address	Parameter	Variable	Size	Min.	Max.	Def.	UoM	Dir.			
Discrete inputs	Unit status Alarms	1	Circuit breaker intervention	Al_CircBreaker.Active	1	0	1			R			
		2	High pressure switch intervention	Al_HiPSwitch.Active	1	0	1			R			
		3	High pressure	Al_HiP.Active	1	0	1			R			
		4	Low pressure	Al_LoP.Active	1	0	1			R			
		5	High pressure on bypass	Al_HiPByPassBlk.Active	1	0	1			R			
		6	High pressure on bypass	Al_HiPByPass.Active	1	0	1			R			
		7	High temperature on bypass	Al_HiTByPassBlk.Active	1	0	1			R			
		8	High temperature on bypass	Al_HiTByPass.Active	1	0	1			R			
		9	Low pressure on bypass	Al_LoPByPass.Active	1	0	1			R			
		10	Zone drain valves error	Al_Drain.Active	1	0	1			R			
		11	Expansion offline	Al_ExpOffline.Active	1	0	1			R			
		12	Warning high temperature on bypass	Wr_HiTByPass.Active	1	0	1			R			
		13	Retain memory error	Al_Retain.Active	1	0	1			R			
		14	Retain memory writes error	Al_RetainWrite.Active	1	0	1			R			
		15	Main probe 1 error	Al_MainPrb_1.Active	1	0	1			R			
		16	Limit probe 1 error	Al_LimPrb_1.Active	1	0	1			R			
		17	Main probe 2 error	Al_MainPrb_2.Active	1	0	1			R			
		18	Limit probe 2 error	Al_LimPrb_2.Active	1	0	1			R			
		19	Low pressure trasducer error	Al_PressByPass.Active	1	0	1			R			
		20	Bypass temperature probe error	Al_TempByPass.Active	1	0	1			R			
		21	High pressure transducer error	Al_Press.Active	1	0	1			R			
		22	Missing model	Al_MissModel.Active	1	0	1			R			
		23	Water treatment system alarm	Al_WTS.Active	1	0	1			R			
		24	Water treatment system alarm	Al_WTS.Active	1	0	1			R			
		25 ÷ 32	Wireless probe offline 1 ÷ 8	Al_WPrb_1 ÷ 8.Active	1	0	1			R			
		33	Main probe 1 from wireless error	Al_WPrbMain_1.Active	1	0	1			R			
		34	Limit probe 1 from wireless error	Al_WPrbLim_1.Active	1	0	1			R			
		35	Main probe 2 from wireless error	Al_WPrbMain_2.Active	1	0	1			R			
		36	Limit probe 2 from wireless error	Al_WPrbLim_2.Active	1	0	1			R			
		37 ÷ 40	Unit 1 ÷ 4 alarm	Al_NetUnit_1 ÷ 4.Active	1	0	1			R			
		41	Change oil	Al_Maint_50.Active	1	0	1			R			
		42	Maintenance	Wr_Maint_1000.Active	1	0	1			R			
		43	Maintenance required	Al_Maint_3000.Active	1	0	1			R			
		Input registers	Unit status	1	Unit status 0: OFF BY KEYB   5: STAND BY   10: MANUAL MODE 1: OFF BY DIN   6: PRODUCTION   11: READY BACKUP 2: OFF BY SV   7: ALARM   12: SWITCH OFF 3: OFF BY SCHED   8: FILL 4: STARTUP   9: WASH	UnitStatus	1	0	12			R	
				2	Request zone 1	ReqMsk_1	2	0	100		[%]	R	
				4	Request zone 2	ReqMsk_2	2	0	100		[%]	R	
				6	Production zone 1	Prod_1	2	0	100		[%]	R	
				8	Production zone 2	Prod_2	2	0	100		[%]	R	
				10	Water consumption 1	WProd_1	2				[Kg/h]/[lb/h]	R	
				12	Water consumption 2	WProd_2	2				[Kg/h]/[lb/h]	R	
				Inputs	14	Main probe 1	MainPrb_1	2				[%rh]/[°C/°F]	R
					16	Main probe 2	MainPrb_2	2				[%rh]/[°C/°F]	R
					18	Limit probe 1	LimPrb_1	2				[%rh]/[°C/°F]	R
20	Limit probe 2				LimPrb_2	2				[%rh]/[°C/°F]	R		
22	Pressure on bypass				PressByPass	2				[bar]/[psi]	R		
24	Pressure on main line				Press	2				[bar]/[psi]	R		
Input registers	Inputs			26	Bypass temperature	TempByPass	2				[°C]/[°F]	R	
		28-32-36-40-44-48-52-56	Humidity from wireless probe 1 ÷ 8	Inputs_WPrbs.WirelessPrbVal_1 ÷ 8.Hum	2				[°C]/[°F]	R			
		30-34-38-42-46-50-54-58	Temperature from wireless probe 1 ÷ 8	Inputs_WPrbs.WirelessPrbVal_1 ÷ 8.Temp	2				[%rh]	R			

Type	Section	Address	Parameter	Variable	Size	Min.	Max.	Def.	UoM	Dir.
Coils	Remote control	1	Alarms reset	Alarms.AlrmResBySV	1	0	1	0		R/W
		2	Unit on/off from supervisor	OnOff_Status.SVOn	1	0	1	0		R/W
Holding registers	Remote control	1	Unit request from supervisor zone 1	Regulation.SVReq_1	2	0	100	0	[%]	R/W
		3	Unit request from supervisor zone 2	Regulation.SVReq_2	2	0	100	0	[%]	R/W
		5	Setpoint zone 1 (humidity)	RegCfg_1.SetP_hum	2	0	100	50	[%rh]	R/W
		7	Setpoint zone 1 (temperature)	RegCfg_1.SetP_temp	2			50	[°C]/[°F]	R/W
		9	Setpoint limit zone 1 (humidity)	RegCfg_1.SetPLim_hum	2	0	100	50	[%rh]	R/W
		11	Setpoint limit zone 1 (temperature)	RegCfg_1.SetPLim_temp	2			50	[°C]/[°F]	R/W
		13	Setpoint zone 2 (humidity)	RegCfg_2.SetP_hum	2	0	100	50	[%]	R/W
		15	Setpoint zone 2 (temperature)	RegCfg_2.SetP_temp	2			50	[°C]/[°F]	R/W
		17	Setpoint limit zone 2 (humidity)	RegCfg_2.SetPLim_hum	2	0	100	50	[%]	R/W
19	Setpoint limit zone 2 (temperature)	RegCfg_2.SetPLim_temp	2			50	[°C]/[°F]	R/W		

Tab. 10.b

### 10.4 List of BACnet parameters

Type	Section	BACNet	Parameter	Variable	Min.	Max.	Def.	UoM	Dir		
Binary values	Unit status	0	Unit on/off	UnitOn					R		
	Alarms	1	Circuit breaker intervention	Al_CircBreaker.Active	0	1			R		
		2	High pressure switch intervention	Al_HiPSwitch.Active	0	1			R		
		3	High pressure	Al_HiP.Active	0	1			R		
		4	Low pressure	Al_LoP.Active	0	1			R		
		5	High pressure on bypass	Al_HiPByPassBlk.Active	0	1			R		
		6	High pressure on bypass	Al_HiPByPass.Active	0	1			R		
		7	High temperature on bypass	Al_HiTByPassBlk.Active	0	1			R		
		8	High temperature on bypass	Al_HiTByPass.Active	0	1			R		
		9	Low pressure on bypass	Al_LoPByPass.Active	0	1			R		
		10	Zone drain valves error	Al_Drain.Active	0	1			R		
		11	Expansion offline	Al_ExpOffline.Active	0	1			R		
		12	Warning high temperature on bypass	Wr_HiTByPass.Active	0	1			R		
		13	Retain memory error	Al_Retain.Active	0	1			R		
		14	Retain memory writes error	Al_RetainWrite.Active	0	1			R		
		15	Main probe 1 error	Al_MainPrb_1.Active	0	1			R		
		16	Limit probe 1 error	Al_LimPrb_1.Active	0	1			R		
		17	Main probe 2 error	Al_MainPrb_2.Active	0	1			R		
		18	Limit probe 2 error	Al_LimPrb_2.Active	0	1			R		
		19	Low pressure trasducer error	Al_PressByPass.Active	0	1			R		
		20	Bypass temperature probe error	Al_TempByPass.Active	0	1			R		
		21	High pressure trasducer error	Al_Press.Active	0	1			R		
		22	Missing model	Al_MissModel.Active	0	1			R		
		23	Water treatment system alarm	Al_WTS.Active	0	1			R		
		24 ÷ 31	Wireless probe offline 1 ÷ 8	Al_WPrb_1 ÷ 8.Active	0	1			R		
		32	Main probe 1 from wireless error	Al_WPrbMain_1.Active	0	1			R		
		33	Limit probe 1 from wireless error	Al_WPrbLim_1.Active	0	1			R		
		34	Main probe 2 from wireless error	Al_WPrbMain_2.Active	0	1			R		
		35	Limit probe 2 from wireless error	Al_WPrbLim_2.Active	0	1			R		
		36 ÷ 39	Unit 1 ÷ 4 alarm	Al_NetUnit_1 ÷ 4.Active	0	1			R		
		40	Change oil	Al_Maint_50.Active	0	1			R		
		41	Maintenance	Wr_Maint_1000.Active	0	1			R		
		42	Maintenance required	Al_Maint_3000.Active	0	1			R		
		Remote control	43	Alarms reset	Alarms.AlrmResBySV	0	1	0		R/W	
			44	Unit on/off from supervisor	OnOff_Status.SVOn	0	1	0		R/W	
		P.I.V.	Unit status	0	Unit status 0: OFF BY KEYB    5: STAND BY    10: MANUAL MODE 1: OFF BY DIN    6: PRODUCTION    11: READY BACKUP 2: OFF BY SV    7: ALARM    12: SWITCH OFF 3: OFF BY SCHED    8: FILL 4: STARTUP    9: WASH	UnitStatus	1	0	12		R
		Analog values	Unit status	0	Request zone 1	ReqMsk_1	0	100		[%]	R
				1	Request zone 2	ReqMsk_2	0	100		[%]	R
				2	Production zone 1	Prod_1	0	100		[%]	R
	3			Production zone 2	Prod_2	0	100		[%]	R	
	4			Water consumption 1	WProd_1				[Kg/h]/[lb/h]	R	
	Inputs		5	Water consumption 2	WProd_2				[Kg/h]/[lb/h]	R	
			6	Main probe 1	MainPrb_1				[%rh]/[°C/°F]	R	
			7	Main probe 2	MainPrb_2				[%rh]/[°C/°F]	R	
8			Limit probe 1	LimPrb_1				[%rh]/[°C/°F]	R		
9			Limit probe 2	LimPrb_2				[%rh]/[°C/°F]	R		
10			Pressure on bypass	PressByPass				[bar]/[psi]	R		
11			Pressure on mail line	Press				[bar]/[psi]	R		
12			Bypass temperature	TempByPass				[°C]/[°F]	R		
13-15-17-19-21-23-25-27			Humidity from wireless probe 1 ÷ 8	Inputs_WPrbs.WirelessPrbVal_1 ÷ 8.Hum				[%rh]	R		
14-16-18-20-22-24-26-28			Temperature from wireless probe 1 ÷ 8	Inputs_WPrbs.WirelessPrbVal_1 ÷ 8.Temp				[°C]/[°F]	R		
Remote control			29	Unit request from supervisor zone 1	Regulation.SVReq_1	0	100	0	[%]	R/W	
			30	Unit request from supervisor zone 2	Regulation.SVReq_2	0	100	0	[%]	R/W	
			31	Setpoint zone 1 (humidity)	RegCfg_1.SetP_hum	0	100	50	[%rh]	R/W	
	32		Setpoint zone 1 (temperature)	RegCfg_1.SetP_temp			50	[°C]/[°F]	R/W		
	33		Setpoint limit zone 1 (humidity)	RegCfg_1.SetPLim_hum	0	100	50	[%rh]	R/W		
	34	Setpoint limit zone 1 (temperature)	RegCfg_1.SetPLim_temp			50	[°C]/[°F]	R/W			
	35	Setpoint zone 2 (humidity)	RegCfg_2.SetP_hum	0	100	50	[%]	R/W			
	36	Setpoint zone 2 (temperature)	RegCfg_2.SetP_temp			50	[°C]/[°F]	R/W			
37	Setpoint limit zone 2 (humidity)	RegCfg_2.SetPLim_hum	0	100	50	[%]	R/W				
38	Setpoint limit zone 2 (temperature)	RegCfg_2.SetPLim_temp			50	[°C]/[°F]	R/W				

Tab. 10.c

# 11. WIRELESS PROBES, INSTALLATION AND CONFIGURATION

## 11.1 Type of installation and wireless probe electrical connections

Wireless probes are available for systems where standard wired probes cannot be used, for example modifications to existing installations. An Access Point (CAREL P/N: WS01AB2M20) is used to connect up to four wireless probes. Recommended Carel wireless probes are the room

(WS01G01M00) or industrial versions (WS01F01M00), both of which measure humidity and temperature. The type of installation is shown in the figure below (referring to four wireless room probes):

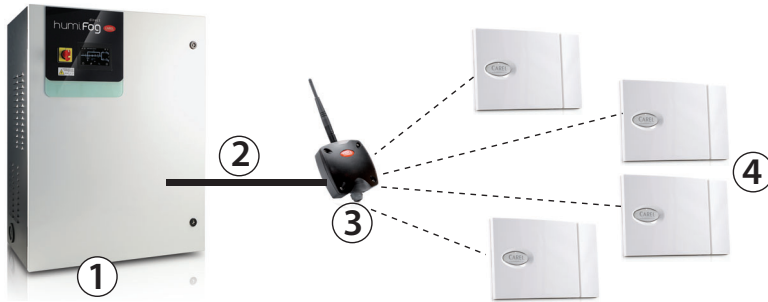

Fig. 11.a

Key:

- 1. humiFog Direct humidifier;
- 2. humidifier/access point connection;
- 3. Access point (WS01AB2M20);
- 4. Wireless probes for measuring temperature and humidity (WS01G01M00 or WS01F01M00).

### humiFog Direct/Access point connection:

To connect the humidifier to the access point, use the Fieldbus connection on terminal M3 (M3.1: Tx/Rx-, M3.2: Tx/Rx+, M3.3: GND):

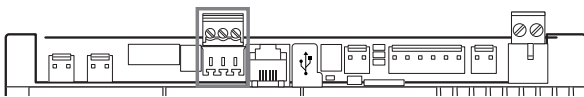

**Note:** the devices have a range of around a hundred metres in a free space, i.e. without any obstacles. In a closed space, the range varies considerably depending on the type of environment and the surrounding objects (shelves, metal partition walls etc.).

If installing multiple wireless probes, the controller will calculate the weighted average between the various probe readings, depending on the settings made by the user and the defined probe groups.

The table below shows the part numbers and descriptions of the Carel devices that can be used:

P/N	Model	Features	Power supply
WS01F01M00	SI Probe	Temperature/humidity for industrial use	Battery
WS01G01M00	SA probe	Room temperature/humidity	Battery
WS01AB2M20	Access Point	Gateway radio ZigBee™ – RS485 Modbus	12/24 Vac/dc ±10% 100 mA; 50/60 Hz; Use a Class II safety transformer with minimum power rating of 2 VA. A 12 Vac transformer is recommended

Tab. 11.a

The address to be used by the access point is set using the dipswitches on the device, and is the following:



This assigns the address 2 to the access point, with a baud rate (bit/sec) of 19200 (N82). The addresses of the four serial probes, on the other hand, must be set as shown in the table below:

	Address	Dipswitch							
		1	2	3	4	5	6	7	8
Probe 1	16	0	0	0	0	1	0	0	0
Probe 2	17	1	0	0	0	1	0	0	0
Probe 3	18	0	1	0	0	1	0	0	0
Probe 4	19	1	1	0	0	1	0	0	0

Tab. 11.b

Remember to verify the quality of the wireless signal between the Access Point and each wireless probe.

For a complete description of the installation procedure, see the Carel manual on the corresponding probes and access point.

To configure the probes refer to screens: Dc13, Dc14, Dc15, Dc16 and Dc17.

In particular, screen Dc03 is used to enable the wireless probes connected to the access point, knowing that addresses 16, 17, 18 and 19 are probe 1, probe 2, probe 3 and probe 4 respectively.

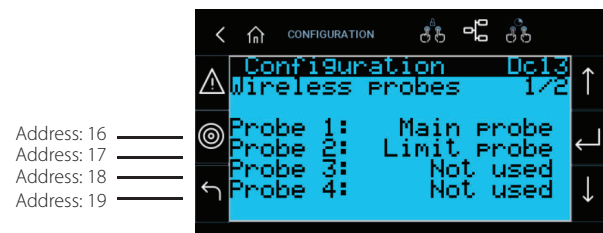

## 11.2 Wireless probe installation

The main steps for installing the wireless devices are:

- power on the access point (12/24 Vac/dc ±10%, 100mA) and complete the initialisation procedure, creating the network and selecting the channel;
- after having opened the domain on the access point, complete the binding procedure so as to uniquely identify each probe.

## 12. ALARM

The following table shows the alarms that can be displayed, with the corresponding description, causes and possible solutions.

Alarm	Code	Cause	Solution	Reset	Alarm relay	Action
Magnetothermic	ABA01	High overload or short circuit current	Verify: <ul style="list-style-type: none"> <li>that the magnetothermal switch is set to the red dot marked by the factory (+15% rated motor current);</li> <li>the absence of short circuits;</li> <li>that the temperature of the environment where the pumping station is installed is according to specification;</li> <li>that the rotation of the pump shaft is not hindered;</li> <li>that maintenance has been carried out on the pump at regular intervals in accordance with this manual.</li> </ul>	Manual	Active	Humidification interrupted
Pressure switch high P	ABA02	Water pressure in discharge > 90 bar	The alarm corresponds to the opening of the HP pressure switch. Verify: <ul style="list-style-type: none"> <li>that the pressure switch is correctly connected to terminals J23-1-J23.2;</li> <li>that the pressure switch contact is closed if the pressure is &lt; 90 bar;</li> <li>the absence of obstructions in the delivery line;</li> <li>the correct calibration of the mechanical bypass valve on the pump.</li> </ul> If necessary, replace the HP pressure switch.	Manual	Active	Humidification interrupted
High pressure RHP probe	ABA03	Water pressure in discharge > 80 bar	The alarm corresponds to a pressure reading from the RHP probe > 80 bar (screen C01). Verify: <ul style="list-style-type: none"> <li>that the RHP probe is correctly connected on terminals J3.3-J3.5 and receives power from J3.1;</li> <li>the absence of obstructions in the delivery line;</li> <li>the correct calibration of the mechanical bypass valve on the pump.</li> </ul> If necessary, replace the RHP probe.	Manual	Active	Humidification interrupted
Low pressure RHP probe	ABA04	Water pressure in discharge < 20 bar for more than 30 s with pump running	The alarm corresponds to a pressure reading from the RHP probe < 20 bar (screen C01). Verify: <ul style="list-style-type: none"> <li>that the RHP probe is correctly connected on terminals J3.3-J3.5 and receives power from J3.1;</li> <li>the absence of leakage on the delivery line;</li> <li>the correct closing operation of the DR1/DR2 zone discharge and BYP bypass discharge solenoid valves (NO valves, 24Vac to close);</li> <li>that filling is enabled with a duration that is appropriate to the length of the water line;</li> </ul> If necessary, replace the RHP probe.	Manual	Active	Humidification interrupted
High bypass pressure	ABA05	Water pressure in bypass > 8 bar or ALA06 alarm triggered more than 3 times in 1 hour	Possible return of pressurised water through the bypass. Verify: <ul style="list-style-type: none"> <li>that the BYP bypass discharge solenoid valve is capable of discharging water;</li> <li>correct operation of the mechanical overflow valve (opens at 4 bar).</li> </ul> If necessary, replace the BYP bypass discharge solenoid valve and/or the overflow valve.	Manual	Active	Humidification interrupted
Very high bypass temperature	ABA07	Bypass water temperature > 65°C	Prolonged recirculation of water through the bypass is possible. Verify: <ul style="list-style-type: none"> <li>that the humidification capacity set on the Dc18 screen is equal to no. of nozzles x capacity of the single nozzle;</li> <li>that the zone is able to supply a water flow rate <math>\geq</math> the minimum flow rate supplied by the pump;</li> <li>that the NTC probe is connected to terminals J5.2-J5.3</li> </ul>	Manual	Active	Humidification interrupted
Low pressure LPS probe	ABA09	No water or water pressure in feed < 0.3 bar	Possible lack of water in the inlet or low pressure in the feed. Verify: <ul style="list-style-type: none"> <li>that the alarm of the reverse osmosis system upstream of humiFog direct is not going off</li> <li>that there is an expansion tank or storage tank with booster pump properly calibrated upstream of the humiFog direct.</li> <li>the functionality of the loading solenoid valve.</li> </ul>	Manual / Automatic	Active	Humidification interrupted (The unit periodically performs up to 30 automatic restart attempts)
High pressure fill/wash	ABA10	Discharge pressure > 2 bar when filling or flushing	Possible obstruction in the delivery line. Verify: <ul style="list-style-type: none"> <li>correct opening of the zone load NC solenoid valves (24Vac when they open);</li> <li>correct opening of the zone discharge NO solenoid valves (0Vac when they open).</li> </ul>	Manual	Active	Humidification interrupted
Disconnected LPS probe	ABP05	LPS pressure probe broken or disconnected	Verify: <ul style="list-style-type: none"> <li>that the LPS probe is correctly connected on terminals J16.1-J16.2 and receives power from J3.1.</li> </ul> Replace the probe if necessary.	Manual	Active	Humidification interrupted

Alarm	Code	Cause	Solution	Reset	Alarm relay	Action
Sonda T bypass disconn	ABP06	Bypass temperature probe broken or disconnected	Verify: • that the NTC probe is connected to terminals J5.2-J5.3. Replace the probe if necessary.	Manual	Active	Humidification interrupted
Sonda RHP disconn	ABP07	RHP pressure probe broken or disconnected	Verify: • that the RHP probe is correctly connected on terminals J3.3-J3.5 and receives power from J3.1. Replace the probe if necessary.	Manual	Active	Humidification interrupted
Modello mancante	ABC01	Machine model not set	Set the machine model to screen Df05 according to the code shown on the cabinet door	Automatic	Active	Humidification interrupted
WTS in allarme	ABE01	Water treatment system alarm	If enabled input from water treatment plant alarm relay Check the water treatment system upstream of humiFog direct	Automatic	Active	Humidification interrupted
Alta press. bypass	ALA06	Bypass water pressure > 4 bar	Possible return of pressurised water through the bypass. Verify: • that the bypass discharge solenoid valve is capable of discharging water; • correct operation of the mechanical overflow valve (opens at 4 bar). If necessary, replace the BYP bypass discharge solenoid valve and/or the overflow valve.	Manual	Active	Signal
Alta temp. bypass	ALA08	WRA12 warning triggered more than 3 times in 1 hour	Prolonged recirculation of water through the bypass is possible. Verify: • that the humidification capacity set on the Dc18 screen is equal to no. of nozzles x capacity of the single nozzle; • that the zone is capable of delivering a water flow rate $\geq$ the minimum flow rate supplied by the pump; • that the NTC probe is connected to terminals J5.2-J5.3	Manual	Active	Signal
c.pCOe offline	ALA11	c.pCOe disconnected from c.phc or wired incorrectly	The c.pCOe expansion that regulates zone 2 is offline. Verify: • the exactness of the machine model (the alarm is triggered if the cabinet is single zone but the c.phc control is configured for dual zone); • that the wiring between c.phc (terminal M3) and c.pCOe (terminal J6 BMS) respects the polarities +, -, GND as shown in the wiring diagram; • that c.pCOe is powered (24Vac between G-G0 on terminal J1).	Automatic	Active	Humidification interrupted
Oil change requested	ALA13	Pump oil change requested	• Change pump oil after first 50 hours of operation, reset hour meter after maintenance	Manual	Active	Signal
Oil change and parts replace requested	ABA15	Pump maintenance request	• Every 3000 hours of operation, maintenance of the mechanical components of the pump and oil change is required, reset hour meter after maintenance	Manual	Active	Signal
Error written. mem. T	ALM01	Electronic control problem	Reload the factory parameters from screen Df06 and reconfigure the unit. If the problem persists, replace the control.	Manual	Active	Signal
Many writtens mem. T	ALM02	Electronic control problem	Reload the factory parameters from screen Df06 and reconfigure the unit. If the problem persists, replace the control.	Manual	Active	Signal
Main probe 1 disconn.	ALP01	Zone 1 main probe broken or disconnected	Check the connection of the zone 1 main probe to terminals M2.1-M2.2-M2.3 of the c.phc	Automatic	Active	Signal
Lim. Probe 1 disconn.	ALP02	Zone 1 limit probe broken or disconnected	Check the connection of the zone 1 limit probe to terminals M2.4-M2.5-M2.3 of the c.phc	Automatic	Active	Signal
Main probe 2 disconn.	ALP03	Zone 2 main probe broken or disconnected	Check the connection of the zone 2 main probe to terminals J2.U1-J2.GND-J9.+Vdc of c.pCOe	Automatic	Active	Signal
Limit probe 2 disconn	ALP04	Zone 2 limit probe broken or disconnected	Check the connection of the zone 2 limit probe to terminals J2.U2-J2.GND-J9.+Vdc of c.pCOe	Automatic	Active	Signal
S. wireless 1 offline	ALP08	No communication with probe 1	Verify: • the probe/access point association • battery status • the signal level of the probe	Automatic	Active	Signal
S. wireless 2 offline	ALP09	No communication with probe 2	Verify: • the probe/access point association • battery status • the signal level of the probe	Automatic	Active	Signal
S. wireless 3 offline	ALP10	No communication with probe 3	Verify: • the probe/access point association • battery status • the signal level of the probe	Automatic	Active	Signal
Wireless probe 4 offline	ALP11	No communication with probe 4	Verify: • the probe/access point association • battery status • the signal level of the probe	Automatic	Active	Signal

Alarm	Code	Cause	Solution	Reset	Alarm relay	Action
Wireless probe 5 offline	ALP12	No communication with probe 5	Verify: <ul style="list-style-type: none"> <li>the probe/access point association</li> <li>battery status</li> <li>the signal level of the probe</li> </ul>	Automatic	Active	Signal
Wireless probe 6 offline	ALP13	No communication with probe 6	Verify: <ul style="list-style-type: none"> <li>the probe/access point association</li> <li>battery status</li> <li>the signal level of the probe</li> </ul>	Automatic	Active	Signal
Wireless probe 7 offline	ALP14	No communication with probe 7	Verify: <ul style="list-style-type: none"> <li>the probe/access point association</li> <li>battery status</li> <li>the signal level of the probe</li> </ul>	Automatic	Active	Signal
Wireless probe 8 offline	ALP15	No communication with probe 8	Verify: <ul style="list-style-type: none"> <li>the probe/access point association</li> <li>battery status</li> <li>the signal level of the probe</li> </ul>	Automatic	Active	Signal
Main probe 1 offline	ALP16	No communication with all wireless probes - main control zone 1	Verify: <ul style="list-style-type: none"> <li>probe connection</li> <li>association of probes with access point</li> <li>access point power supply</li> </ul>	Automatic	Active	Signal
Limit probe 1 offline	ALP17	No communication with all wireless probes - limit control zone 1	Verify: <ul style="list-style-type: none"> <li>probe connection</li> <li>association of probes with access point</li> <li>access point power supply</li> </ul>	Automatic	Active	
Main probe 2 offline	ALP18	No communication with all wireless probes - main control zone 2	Verify: <ul style="list-style-type: none"> <li>probe connection</li> <li>association of probes with access point</li> <li>access point power supply</li> </ul>	Automatic	Active	Signal
Limit probe 2 offline	ALP19	No communication with all wireless probes - limit control zone 2	Verify: <ul style="list-style-type: none"> <li>probe connection</li> <li>association of probes with access point</li> <li>access point power supply</li> </ul>	Automatic	Active	Signal
Unit 1 in alarm	ALN01	Network unit no. 1 in alarm	Only if network function is active Perform checks according to the alarm displayed on the machine concerned	Automatic	Active	Signal
Unit 2 in alarm	ALN02	Network unit no. 2 in alarm	Only if network function is active Perform checks according to the alarm displayed on the machine concerned	Automatic	Active	Signal
Unit 3 in alarm	ALN03	Network unit no. 3 in alarm	Only if network function is active Perform checks according to the alarm displayed on the machine concerned	Automatic	Active	Signal
Unit 4 in alarm	ALN04	Network unit no. 4 in alarm	Only if network function is active Perform checks according to the alarm displayed on the machine concerned	Automatic	Active	Signal
High bypass temperature	WRA12	Bypass water temperature > 50°C	Prolonged recirculation of water through the bypass is possible. Verify: <ul style="list-style-type: none"> <li>that the humidification capacity set on the Dc18 screen is equal to no. of nozzles x capacity of the single nozzle;</li> <li>that the zone is capable of delivering a water flow rate <math>\geq</math> the minimum flow rate supplied by the pump;</li> <li>that the NTC probe is connected to terminals J5.2-J5.3</li> </ul>	-	Not Active	Notice
Visual hydraulic check	WRA14	Pump check required	Every 1000 operating hours check the wear condition of the oil and the pump	Manual	Not Active	Signal
Low pressure	-	Pressure measured by RHP probe < 60 bar with active pump	Possible small leak in water delivery, check the tightening of the pipe fittings and the absence of leakage from the DR1 and DR2 discharge solenoid valves. Verify that the pump is capable of delivering the required flow rate to meet the nozzle load.	-	Not Active	Notice

Tab. 12.a

## 13. MAINTENANCE

### 13.1 Hygienic aspects

Hygiene measures are essential for the safe operation of the humidification system in order to protect the occupants of the building from health risks. In principle, the requirements for air humidification according to VDI 6022-1 must be observed. All tests and measurements shall be documented in a logbook available for inspection. The user is responsible for compliance with local regulations and applicable guidelines. Any risk must be identified, including during installation and maintenance, by the Health and Safety Manager, whose role it is to introduce appropriate and effective control measures.

**WARNING:** If improperly maintained, the humidification system and the reverse osmosis system could develop the growth of microorganisms in the pipes, including the bacteria responsible for Legionella, which would then be spread into the environment through the aerosol produced by the atomising nozzles of the blower units. Contaminants can settle on surfaces, be inhaled by people or be distributed by ventilation systems. Comply with the inspection schedules listed under "Hygiene measures".

**WARNING:** Do not keep the humidification system and reverse osmosis system disconnected for more than 48 hours. Without a power supply, the system is unable to perform automatic flushes. Keep the factory-set automatic flushes enabled on both the reverse osmosis unit and the humiFog direct system. If it is necessary to shut down the system for more than 48 hours by disconnecting the power supply, the procedure described in the section "Shutting down the system" must be followed.

#### 13.1.1 Shutting down the system

Whenever the humidification system is shut down for more than 48 hours, the following steps are required:

- emptying;
- cleaning;
- drying;
- washing before service is restored.

Emptying is automatic thanks to the normally open solenoid valves which, in the absence of power supply or after 48 hours with power supply present, allow drainage by gravity. Make sure that the slopes of the high-pressure pipes are such as to favour the discharge through the appropriate solenoid valves. Disconnect the high-pressure hoses connected to the pumping station and the blower units, check that there is no residual water in them and empty them if necessary. The expansion tank or the storage tank interposed between the reverse osmosis system and the demineralised water inlet to the pumping station must be emptied by opening the appropriate manual valve (#8 in the "Functional diagram" chapter). Drain the water filter (#12 in the "Functional diagram" chapter) at the pumping station inlet.

Cleaning shall be carried out manually or by physical means on surfaces in contact with water, e.g. by hot water or compressed air, but not chemically. Chemical disinfection is only permitted following proven microbiological contamination and must be conducted by qualified personnel in accordance with VDI 6022-6:2018-01 Chapter 9 and any subsequent additions. In such cases, disinfectants that do not pose a health risk and do not promote the development of resistance must be used. The tubes should be dried with compressed air. When the power supply is restored for humidification system start-up, humiFog direct will run an automatic washing and filling cycle if enabled (see paragraph "Washing"; factory default: enabled with duration 4 minutes).

#### 13.1.2 Hygiene measures

Below is the list of preventive hygiene checks and the frequency with which they must be carried out, as provided by VDI 6022-6 guidelines and applicable to the humiFog direct system.

Activity	Action if necessary	Weekly	3 months	6 months
Visual verification of the absence of biofilm, algae, deposits, excess of atomised water	Cleaning and restoration	X		
Odour-free verification	Cleaning and restoration	X		
Screening test for the determination of the number of colonies by dip slides according to VDI 6022-1, permissible threshold < 100 CFU/ml (incubation at 30°C from 48 to 72 h)	Cleaning and restoration		X	
Qualified sample (Legionella < 100 CFU/100 ml; Pseudomonas aeruginosa < 100 CFU/100 ml; total CFU at 20°C and 36°C respectively < 150 CFU/ml)	Cleaning and restoration			X
Check for deposits around the nozzle orifice	Nozzle cleaning or replacement		X	
Exhaust test	Cleaning and restoration		X	
Humidity probe function test and limit probe intervention test if present	Restoration			X

Tab. 13.a

If the threshold values in the table are exceeded, the frequency of the activity should be halved until stable results below the prescribed threshold are obtained. Conversely, if the threshold values are met for at least one year, the inspection intervals can be adapted gradually. The detection of biofilm in equipment is always evidence of microbiological contamination and consequent risk to human health. This outcome is critical and necessarily requires the following immediate actions:

1. shutting down the system;
2. removal of biofilm by means of an appropriate cleaning technique;
3. microbiological testing of the surface and disinfection, where the result of the microbiological testing indicates contamination;
4. determination of the cause of biofilm formation;
5. long-term elimination of the identified cause;
6. if the cause cannot be eliminated, the humidification system must be taken out of service.

It is possible to use the thermal disinfection technique in advance by bringing the water to 70°C (158°F) and keeping it in the system for at least 3 minutes. Only after proven microbiological contamination are disinfection techniques and listed chemical disinfectants permitted (see Robert Koch Institute website). The effectiveness of alternative techniques must be verified and demonstrable. The success of the disinfection operation must be proven by appropriate microbiological tests.

### 13.2 Routine maintenance

Routine maintenance is recommended every three months, and mainly involves visual inspection of correct operation of the main components.

The following is a list of recommended operations:

- **Check water inlet filter.**

It is recommended to change the filter cartridge once every 6-12 months. To change the cartridge, switch the unit off and close the feedwater line. Empty the filter using the small tap at the bottom. Empty the filter container through the small tap at the bottom. Remove the filter cartridge inside and fit a new one (P/N ECKFILT050). Tighten the holder, ensuring that the O-ring is still in good condition to ensure tightness. Close the tap under the holder and open the feedwater line.

- **Check pump oil level.**

To check the level visually, use a mirror that allows a view of side of the pump facing to the cabinet wall. There is a small mark behind a circular transparent Plexiglas cover. The oil level is correct if, with the unit off, it remains around the central circumference. If the level is lower than the minimum shown in the figure, top up with oil (SAE 15W40) to the correct level (oil P/N 5024646AXX).

Generally the oil level should remain constant and periodical top ups should not be needed. If oil leaks are found, contact CAREL.

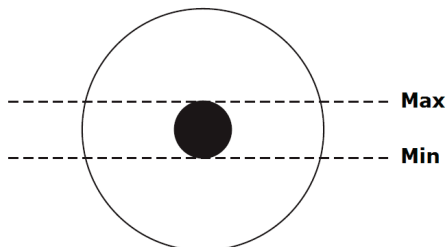

Fig. 13.a

- **Check the nozzles: make sure the spray cone from the nozzles is regular.**

Even when using demineralised water, some particle may at times build-up on the nozzle opening, making the spray cone less uniform and affecting absorption efficiency. If this happens, remove the nozzle (unscrew using a 10 mm spanner) and clean it (immersing in acetic acid to remove scale) or replace it (P/N UAKMTP%000). Before assembling the nozzle again, remove the residual Teflon from the thread and the small white filter at the base of the nozzle, and apply the sealant again to ensure water tightness.

- **Check the fans**

Make sure that all of the fans on the blower units are working. In the event of malfunctions, check the power supply wiring. If the wiring is OK, replace the fan.

- **Check** that there are no water leaks inside cabinet and on the distribution line and fittings.

### 13.3 Special maintenance

Special maintenance involves all those operations that are performed on a one-off basis in the event of malfunctions or breakages of certain components.

The following components are those susceptible to breakage:

- solenoid valves
- pressure reducer
- pressure switches
- pump motor
- pump
- electronic controller
- fuses
- nozzles
- nozzle manifold
- fans on the blower units

To replace these contact specialist and authorised personnel.

To find the replacement part number, see the paragraph "Cabinet spare parts"

### 13.4 Pump maintenance

The pump is the most complex mechanical device inside the cabinet, as well as the heart of the high pressure system. It therefore requires regular maintenance, involving the operations described below.

Pump	monthly	every 1000 h
Check/replace		
check oil level	x	
check/change oil		x
check/replace gaskets and valves		x

Tab. 13.a

#### 13.4.1 Oil change

**Important:** after the first 50 hours of operation, the oil in the pump needs to be changed (P/N 5024646AXX). Failure to change the oil after the first 50 hours may cause damage to the pump and reduce its working life. The first oil supplied, in fact, will accumulate debris due to transport and commissioning, and a longer operating time cannot be guaranteed.

**! Important:** change the pump oil after the first 50 hours of operation.

**! Important:** if there are no leaks or faults, when the "1000 h" check warning is shown, the oil change may be postponed.

Under normal operating conditions, except for the first oil change after only 50 hours, we recommend an oil change every 3000 hours of operation. Every 1000 hours, a notification is generated by the electronic controller and the 3000 hours of operation are signalled by the electronic controller through an appropriate "request for oil change and parts replacement" alarm, which appears on the display.

To change the oil, follow the sequence described below (with the unit off and the water line closed):

7. Remove the yellow cap on the top of the pump and unscrew the oil drain plug attraction the bottom (steel hexagonal plug).
8. Empty the oil into a suitable container. Close the plug.
9. Dispose of the oil in accordance with local standards.
10. Fill the pump body with SAE 15W40 mineral oil, up to the level suggested by the circular marker on the side of the pump (the required oil content is around 350 ml).
11. Finally, close the yellow cap on the top of the pump.

#### 13.4.2 Gasket and valve replacement

The gaskets and valves must be replaced every 3000 hours, duly indicated by the "request for oil change and parts replacement" alarm on the display. Nonetheless, in specific conditions of stress replacement may be needed earlier. Carel recommends to check the pump operation every 1000 operating hours (signalled by notification). If the pump makes noise, or is not able to reach the required operating pressure (70 bars), the gaskets and valves may need to be replaced sooner.

Valves and gaskets are consumables, and wear does not reflect a product malfunction.

To replace the gaskets, proceed as follows:

1. Disconnect the wiring from the high pressure switch, solenoid valve BYP and the NTC probe.
2. Disconnect the pump outlet hose (at the top right).
3. Unscrew the eight hex screws that hold the pump head to the guard.
4. Remove the gaskets and replace them with new ones (P/N UAKVGO1501).
5. Tighten the eight hex screws so as to secure the pump head to the guard.
6. Connect the outlet hose to the pump.
7. Reconnect the pressure switch, solenoid valve and NTC probe

To replace the valves, proceed as follows:

1. Unscrew the three hexagonal caps on the front of the brass pump head.
2. Unscrew the three hexagonal caps on the top of the brass pump head.
3. Replace the six valves with new ones (P/N UAKVGO1501).
4. Tighten the six caps removed previously.

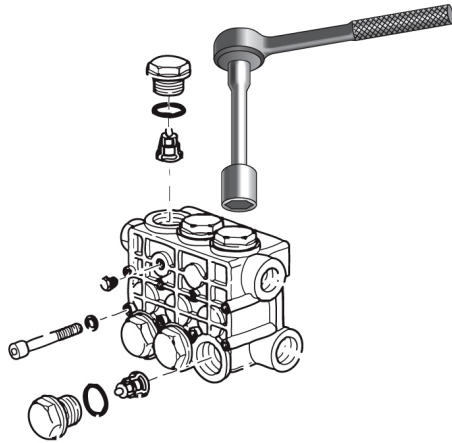

Fig. 13.b

### 13.5 50 hour oil change warning

The first "oil change required" maintenance warning is shown after 50 operating hours: this indicates that the oil needs to be changed immediately. This warning is typically displayed a few days after the systems is first started. Therefore when starting the system, make sure a spare can of oil is available for the first oil change, in accordance with the procedure described in paragraph "Oil change".

The warning can be easily reset by pressing the "Alarm" button on the user interface (button at the top left).

For practical reasons, the warning can also be reset after 40 operating hours, entering the "control menu > screen Da10". The warning cannot be reset before 40 operating hours.

### 13.6 Notification, maintenance warning, reset hour counter

After 1000 of operation, humiFog direct generates a non-blocking "visual hydraulic check" notification. This is a warning that tells the user to check correct operation of the system. If the pump can reach the nominal operating pressure of 70 bars, no action needs to be taken.

The notification can be easily reset by pressing the "alarm" button on the user interface (top left button).

The same occurs after 2000 hours of operation.

After 3000 hours of operation, instead, humiFog direct generates a non-blocking "request for oil change and parts replacement" alarm. In this case, the machine must be serviced by changing the oil and replacing the pump gaskets and valves ("Changing the oil" and "Changing the gaskets and valves").

Will be necessary subsequently reset the alarm in the menu "Control > screen Da10" and press subsequently the "Alarm" button of the display. If for some reason the gaskets and valves need to be replaced before 3000 operating hours, the hour counter needs to be reset on screen Da10. It is recommended, whenever replacing the gaskets and valves, to also change the oil before resetting the hour counter.

### 13.7 Blower spare parts

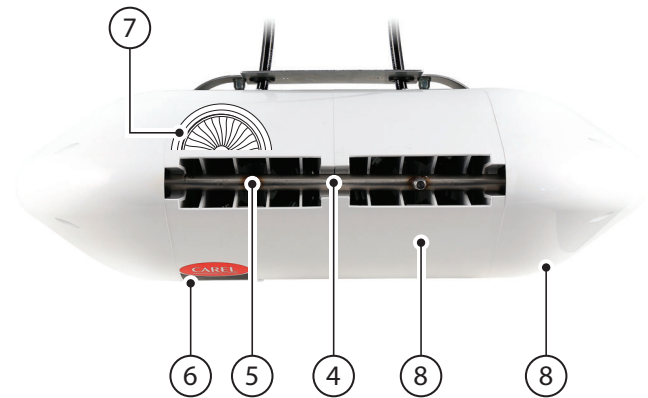
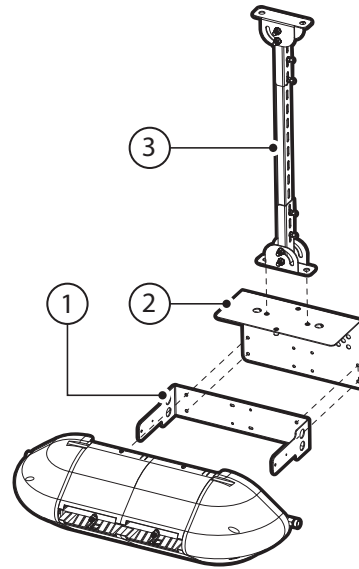

Fig. 13.c

No.	Description	Code
1	Wall mounting bracket, single blower, 2 nozzles (DLA02*F*00)	UAKHW20000
	Wall mounting bracket, single blower, 4 nozzles (DLA04*F*00)	UAKHW40000
2	Ceiling mounting adapter, single blower, 2 nozzles (DLA02*F*00)	UAKHC20000
	Ceiling mounting adapter, single blower, 4 nozzles (DLA04*F*00)	UAKHC40000
3	Ceiling mounting bracket, L = 0.5 m	UAKVC00500
	Ceiling mounting bracket, L = 1.0 m	UAKVC01000
4	2 nozzle water manifold, single blower	Contact CAREL
	4 nozzle water manifold, single blower	Contact CAREL
	4 nozzle water manifold, double blower	Contact CAREL
	8 nozzle water manifold, double blower	Contact CAREL
5	Individual nozzle, flow-rate 1.45 l/h @ 70 bars	UAKMTP0000
	Individual nozzle, flow-rate 2.8 l/h @ 70 bars	UAKMTP1000
	Individual nozzle, flow-rate 4.0 l/h @ 70 bars	UAKMTP2000
6	Power LED	Contact CAREL
7	CE fan – 230 V 50 Hz	Contact CAREL
	UL fan – 120 V 60 Hz	Contact CAREL
8	Plastic cover	Contact CAREL

Tab. 13.b

13.8 Spare parts

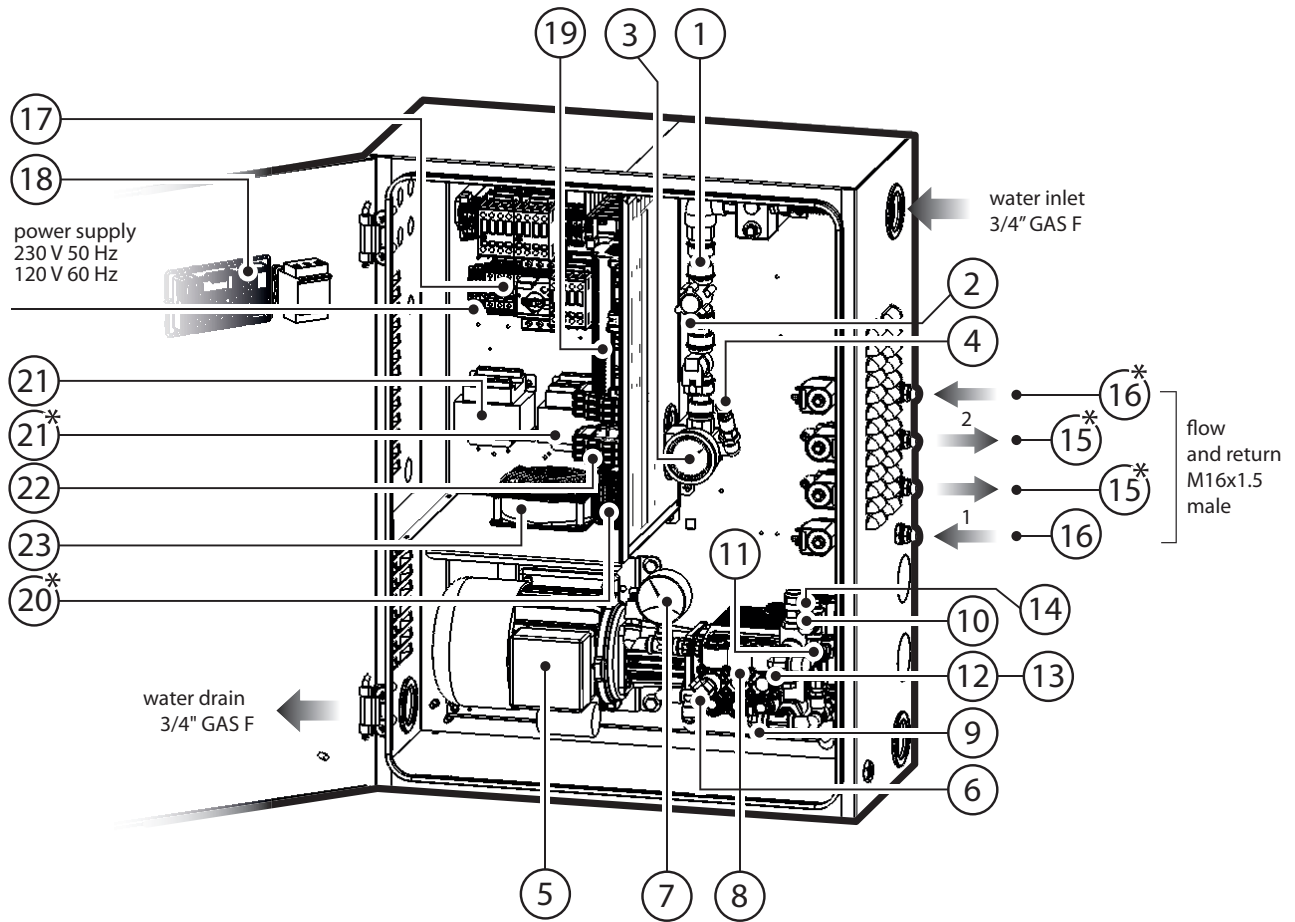

Fig. 13.d

No.	Description	Code
1	Pressure reducer	UAKRID0010
2	N.C. fill solenoid valve	ECKFVS0000
3	Low pressure gauge, scale 0-12 bars, rear fitting 1/4" GAS	MCKMA12000
4	LPS pressure transducer on low pressure inlet line	SPKT0011C3
5	CE motor, 4 poles, 180 W power (for UA040DD%00)	UAKM018F51
	CE motor, 4 poles, 370 W power (for UA080DD%00)	UAKM037F51
	UL motor, 4 poles, 180 W power (for UA050DU%00)	UAKM018F52
	UL motor, 4 poles, 370 W power (for UA090DU%00)	UAKM037F52
6	40-50 l/h pump kit, brass	UAKP040M00
	80-90 l/h pump kit, brass	UAKP080M00
	Valve and gasket kit for pump (for all humiFog Direct models)	UAKVGO1501
	Replacement oil	5024646AXX
7	High pressure gauge, scale 0-100 bars, radial fitting 1/4" GAS	UAKMWHP001
8	Pump high pressure switch (calibration 90 bars)	UAKPSHP000
9	Temperature-controlled safety valve	1309549AXX
10	RHP pressure transducer on high pressure outlet line	UAKSPHPA00
11	NTC probe for measuring bypass water temperature	NTC030WH01
12	Mechanical overflow valve, brass	Contact CAREL
13	Pump drain solenoid valve, 1/8" GAS fitting	UAKDRC0003
14	Bypass solenoid valve	UAKFL00000
15	N.C. fill solenoid valve	UAKFL00000
16	N.O. return solenoid valve	UAKDR00000
17	Fuse kit (see paragraph 2.3.1)	UAKFUSEDRO
18	pGDx display	HCTXDAR000

No.	Description	Code
19	c.pHC programmed for humiFog Direct	UAKCPHCD00
20	c.pCOe for humiFog Direct (two-zone cabinet only, plug & play)	P+E0000000000
21	Transformer for CE cabinet (1 for single zone, 2 for two-zone)	URKTR20000
	Transformer for UL cabinet (1 for single zone, 2 for two-zone)	Contact CAREL
22	SSR relay, Vdc (1 for single zone, 4 for two-zone)	UAKRES2411
	SSR relay, Vac (one for all models)	UAKRES2401
23	Pump motor cooling fan	1312545AXX

Tab. 13.c

# 14. APPENDIX

## 14.1 Single-zone wiring diagram

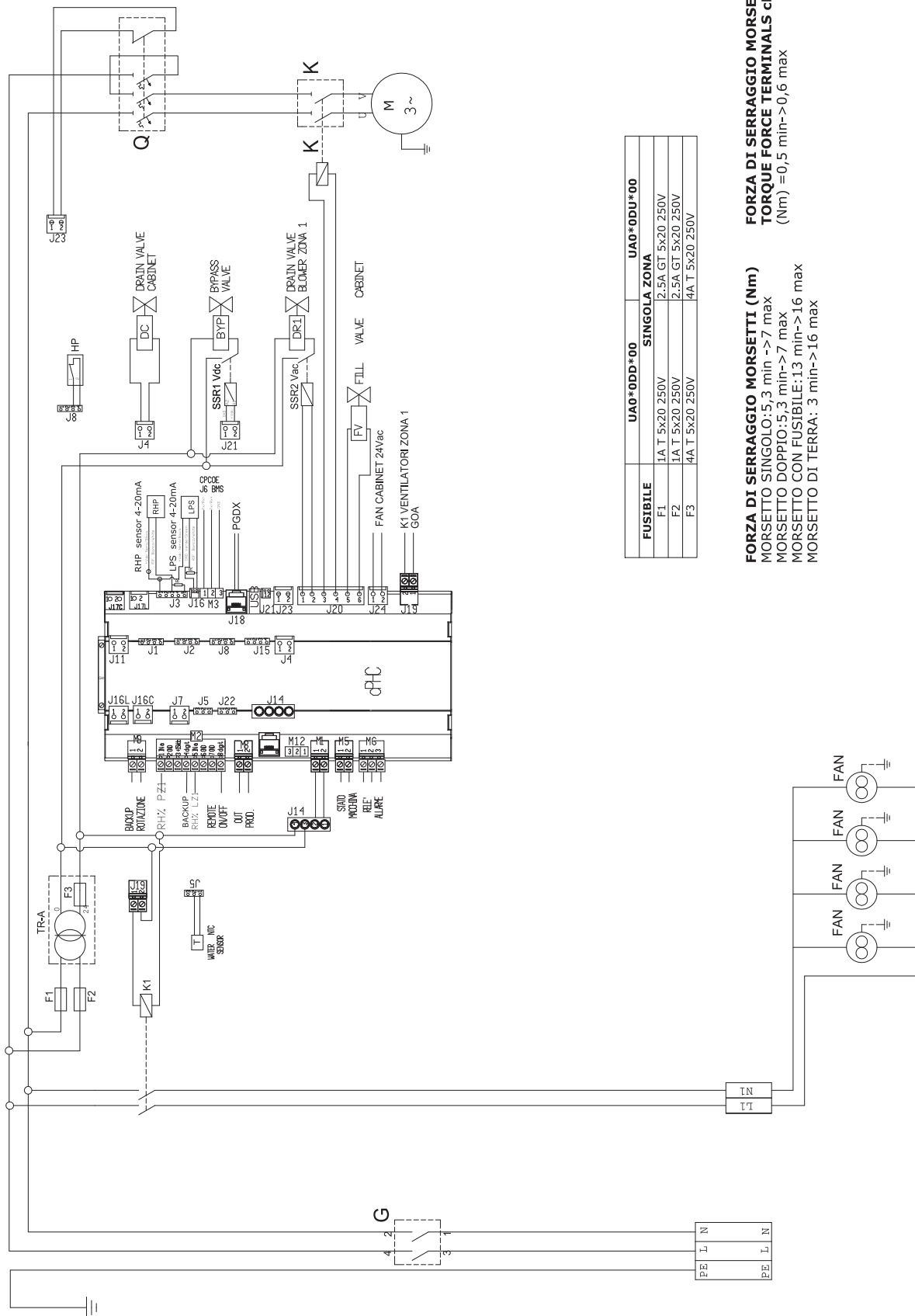

**FORZA DI SERRAGGIO MORSETTI cPHC**  
**TORQUE FORCE TERMINALS cPHC**  
 (Nm) = 0,5 min->0,6 max

**FORZA DI SERRAGGIO MORSETTI (Nm)**  
 MORSETTO SINGOLO: 5,3 min->7 max  
 MORSETTO DOPIO: 5,3 min->7 max  
 MORSETTO CON FUSIBILE: 13 min->16 max  
 MORSETTO DI TERRA: 3 min->16 max

Fig. 14.a

14.2 Two-zone wiring diagram

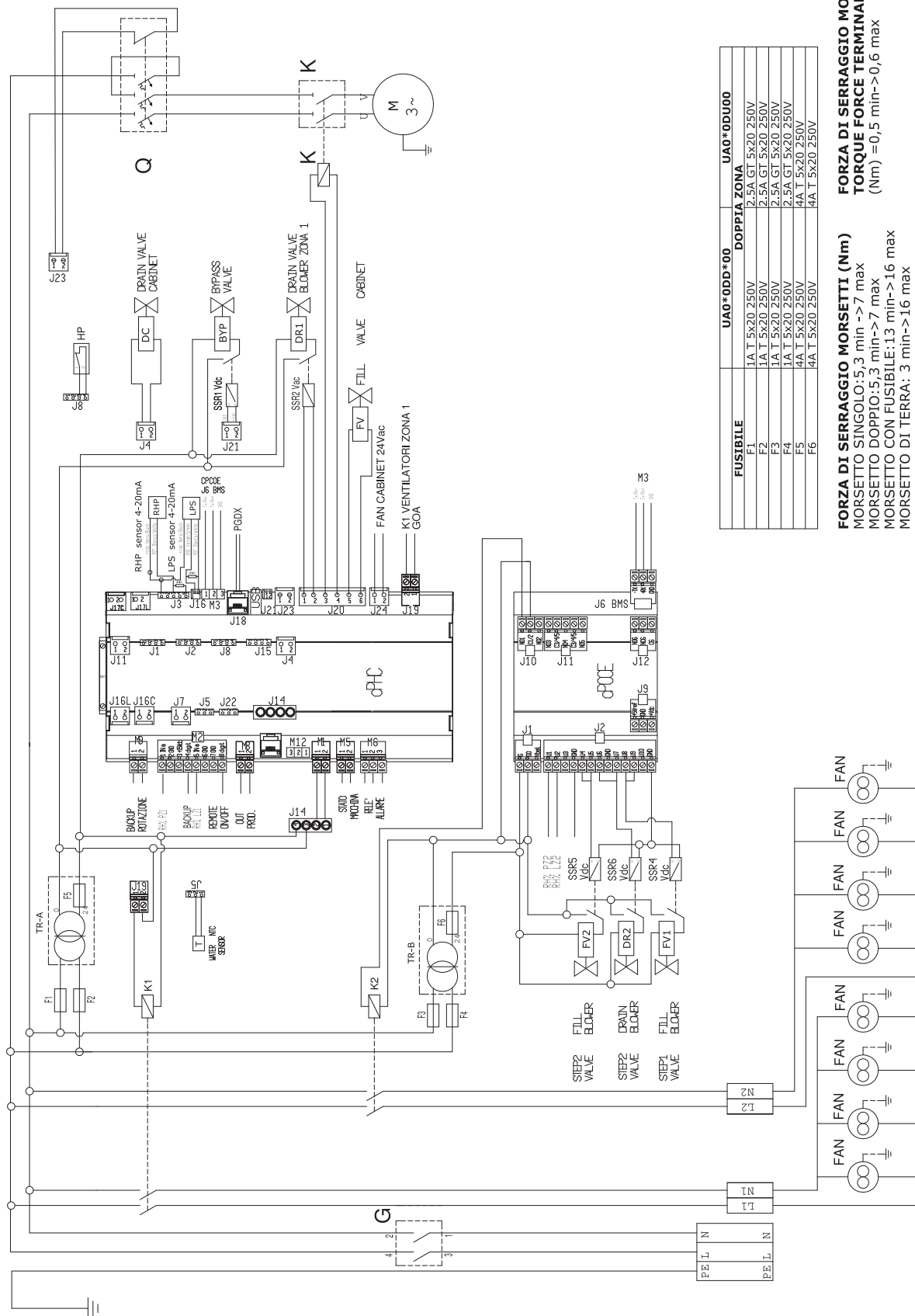

FUSIBILE	UA0*0DD*00	UA0*0DU00
F1	1A T 5x20 250V	DOPPIA ZONA
F2	1A T 5x20 250V	2-BA GT 5x20 250V
F3	1A T 5x20 250V	2-BA GT 5x20 250V
F4	1A T 5x20 250V	2-BA GT 5x20 250V
F5	1A T 5x20 250V	2-BA GT 5x20 250V
F6	4A T 5x20 250V	4A T 5x20 250V

**FORZA DI SERRAGGIO MORSETTI cPHC**  
**TORQUE FORCE TERMINALS cPHC**  
 (Nm) = 0,5 min->0,6 max

**FORZA DI SERRAGGIO MORSETTI (Nm)**  
 MORSETTO SINGOLO: 5,3 min->7 max  
 MORSETTO DOPPIO: 5,3 min->7 max  
 MORSETTO CON FUSIBILE: 13 min->16 max  
 MORSETTO DI TERRA: 3 min->16 max

Fig. 14.b

### 14.3 Datasheets

#### 14.3.1 CE version cabinet datasheet

PHYSICAL SPECIFICATIONS	UA040DD*01	UA080DD*01
Dimensions	630 x 800 x 300 mm	630 x 800 x 300 mm
Weight	60 kg (single-zone)	64 kg (single-zone)
	64 kg (two zones)	68 kg (two zones)
Packaged dimensions	720 x 1020 x 460 mm	720 x 1020 x 460 mm
Packaged weight	64 kg (single-zone)	68 kg (single-zone)
	68 kg (two zones)	72 kg (two zones)
Delivery and storage temperature and humidity	-10/50°C 0-90% rH	-10/50°C 0-90% rH
Operating temperature and humidity	2/40°C 5-95% rH	2/40°C 5-95% rH
IP rating	IP20	IP20
Conformity	EN60204-1 2006; EN61000-6-2 2006; EN61000-6-4 2007	EN60204-1 2006; EN61000-6-2 2006; EN61000-6-4 2007

Tab. 14.a

ELECTRICAL SPECIFICATIONS	UA040DD*01	UA080DD*01
Power supply	230 V 50 Hz single-phase	230 V 50 Hz single-phase
Cabinet power cable	AWG 14	AWG 14
Power (cabinet only, without blowers)	0.28 kW (single-zone)	0.47 kW (single-zone)
	0.38 kW (two zones)	0.57 kW (two zones)
Current (cabinet only, without blowers)	2.5 A (single-zone)	3.5 A (single-zone)
	3.0 A (two zones)	4.0 A (two zones)
Maximum power (cabinet with blowers)	0.81 kW (single-zone)	1.0 kW (single-zone)
	0.91 kW (two zones)	1.1 kW (two zones)
Maximum current (cabinet with blowers)	4.8 A (single-zone)	7.1 A (single-zone)
	5.0 A (two zones)	7.6 A (two zones)
FLA (Full Load Amperes)	0.25HP/180W 2 A	0.5HP/370W 3 A
SCCR (Short Circuit Current Rating)	5 kA	5 kA
Minimum cable size required for blower power supply	AWG 14	AWG 14

Tab. 14.b

WATER CIRCUIT SPECIFICATIONS	UA040DD*01	UA080DD*01
Required feedwater quality	demineralised	demineralised
Feed water temperature	5...20°C/41...68°F	5...20°C/41...68°F
Required feedwater conductivity	5-80 µS/cm	5-80 µS/cm
Required feedwater pressure	3-8 bars	3-8 bars
Water inlet connection	3/4" GAS F	3/4" GAS F
Water drain connection	1/2" GAS F	1/2" GAS F
Water outlet connection	1/4" GAS F	1/4" GAS F
Water outlet pressure	70 bars	70 bars
Maximum capacity	40 l/h	80 l/h

Tab. 14.c

FUNCTIONAL SPECIFICATIONS	UA040DD*01	UA080DD*01
Number of probes allowed (temperature and/or humidity)	1 (single-zone) + limit	1 (single-zone) + limit
	2 (two-zone) + limit	2 (two-zone) + limit
External signal or type of probes	0-10 V, 4-20 mA, 0-1 V, 2-10 V, 0-20 mA, NTC probe	0-10 V, 4-20 mA, 0-1 V, 2-10 V, 0-20 mA, NTC probe
Multi-probe	available	available
Web server	available	available
Serial communication (via Ethernet and/or via RS485)	Modbus, BACnet	Modbus, BACnet

Tab. 14.d

#### 14.3.2 UL version cabinet datasheet

PHYSICAL SPECIFICATIONS	UA050DU*01	UA090DU*01
Dimensions	630 x 800 x 300 mm	630 x 800 x 300 mm
Weight	60 kg (single-zone)	64 kg (single-zone)
	64 kg (two zones)	68 kg (two zones)
Packaged dimensions	720 x 1020 x 460 mm	720 x 1020 x 460 mm
Packaged weight	64 kg (single-zone)	68 kg (single-zone)
	68 kg (two zones)	72 kg (two zones)
Delivery and storage temperature and humidity	-10/50°C 0-90% rH	-10/50°C 0-90% rH
Operating temperature and humidity	2/40°C 5-95% rH	2/40°C 5-95% rH
IP rating	IP20	IP20
Conformity	UL998	UL998

Tab. 14.e

ELECTRICAL SPECIFICATIONS	UA050DU*01	UA090DU*01
Power supply	120 Vac 60 Hz single-phase	120 Vac 60 Hz single-phase
Cabinet power cable	AWG 14	AWG 12
Power (cabinet only, without blowers)	0.28 kW (single-zone)	0.47 kW (single-zone)
	0.38 kW (two zones)	0.57 kW (two zones)
Current (cabinet only, without blowers)	5.0 A (single-zone)	8.0 A (single-zone)
	5.8 A (two zones)	8.8 A (two zones)
Maximum power (cabinet with blowers)	0.74 kW (single-zone)	0.93 kW (single-zone)
	0.84 kW (two zones)	1.03 kW (two zones)
Maximum current (cabinet with blowers)	10.3 A (single-zone)	13.3 A (single-zone)
	11.0 A (two zones)	14.0 A (two zones)
FLA (Full Load Amperes)	0.25HP/180W 4.2 A	0.5HP/370W 7.1 A
SCCR (Short Circuit Current Rating)	5 kA	5 kA
Minimum cable size required for blower power supply	AWG 14	AWG 12

Tab. 14.f

WATER CIRCUIT SPECIFICATIONS	UA050DU*01	UA090DU*01
Required feedwater quality	demineralised	demineralised
Feed water temperature	5...20°C/41...68°F	5...20°C/41...68°F
Required feedwater conductivity	5-80 µS/cm	5-80 µS/cm
Required feedwater pressure	3-8 bars	3-8 bars
Water inlet connection	3/4" GAS F	3/4" GAS F
Water drain connection	1/2" GAS F	1/2" GAS F
Water outlet connection	1/4" GAS F	1/4" GAS F
Water outlet pressure	70 bars	70 bars
Maximum capacity	50 l/h	90 l/h

Tab. 14.g

FUNCTIONAL SPECIFICATIONS	UA050DU*01	UA090DU*01
Number of probes allowed (temperature and/or humidity)	1 (single-zone) + limit	1 (single-zone) + limit
	2 (two-zone) + limit	2 (two-zone) + limit
External signal or type of probes	0-10 V, 4-20 mA, 0-1 V, 2-10 V, 0-20 mA, NTC probe	0-10 V, 4-20 mA, 0-1 V, 2-10 V, 0-20 mA, NTC probe
Multi-probe	available	available
Webserver	available	available
Serial communication (via Ethernet and/or via RS485)	Modbus, BACnet	Modbus, BACnet

Tab. 14.h

### 14.3.3 CE version blower datasheet

Single blower units (for wall-mounting)	DLA02DF*00	DLA04DF*00
Dimensions	640 x 200 x 180 mm	940 x 200 x 180 mm
Weight	4.5 kg	5.6 kg
Packaged dimensions	755 x 235 x 295 mm	1050 x 235 x 295 mm
Packaged weight	5.7 kg	7.4 kg
Delivery and storage temperature	-10/50°C 0-90%	-10/50°C 0-90%
Operating temperature	2/40°C 5-95%	2/40°C 5-95%
Ingress protection (IP)	IP10	IP10
Conformity	CE	CE
Water fitting	M16x1.5 Male	M16x1.5 Male
Water outlet	M16x1.5 Male	M16x1.5 Male
Number of nozzles	2	4
Flow-rate (depending on the type of nozzles)	3.0 l/h - 5.6 l/h - 8.0 l/h	6.0 l/h - 11.2 l/h - 16.0 l/h
Power supply	230 Vac 50 Hz	230 Vac 50 Hz
Fan total air flow-rate	300 m3/h	600 m3/h
Blower connection cable	AWG 14	AWG 14
Maximum number of blower units (connected to one cabinet)	12	6

Tab. 14.i

Double blower units (for mounting in centre of corridor) CE version	DLA04DB*00	DLA08DB*00
Dimensions	640 x 200 x 400 mm	940 x 200 x 400 mm
Weight	9.2 kg	15.5 kg
Packaged dimensions	755 x 470 x 295 mm	1050 x 470 x 295 mm
Packaged weight	11.4 kg	18.0 kg
Delivery and storage temperature	-10/50°C 0-90%	-10/50°C 0-90%
Operating temperature	2/40°C 5-95%	2/40°C 5-95%
Ingress protection (IP)	IP10	IP10
Conformity	CE	CE
Water fitting	M16x1.5 Female	M16x1.5 Female
Water outlet	M16x1.5 Female	M16x1.5 Female
Number of nozzles	4	8
Flow-rate (depending on the type of nozzles)	6.0 l/h - 11.2 l/h - 16.0 l/h	12.0 l/h - 22.4 l/h - 32 l/h
Power supply	230 Vac 50 Hz	230 Vac 50 Hz
Fan total air flow-rate	600 m3/h	1,200 m3/h
Blower connection cable	AWG 14	AWG 14
Maximum number of blower units (connected to one cabinet)	6	3

Tab. 14.j

14.3.4 UL version blower datasheet

Single blower units (for wall-mounting) UL version	DLA02UF*00	DLA04UF*00
Dimensions	640 x 200 x 180 mm	940 x 200 x 180 mm
Weight	4.5 kg	5.6 kg
Packaged dimensions	755 x 235 x 295 mm	1050 x 235 x 295 mm
Packaged weight	5.7 kg	7.4 kg
Delivery and storage temperature	-10/50°C 0-90%	-10/50°C 0-90%
Operating temperature	2/40°C 5-95%	2/40°C 5-95%
Ingress protection (IP)	IP10	IP10
Conformity	UL	UL
Water fitting	M16x1.5 Male	M16x1.5 Male
Water outlet	M16x1.5 Male	M16x1.5 Male
Number of nozzles	2	4
Flow-rate (depending on the type of nozzles)	3.0 l/h - 5.6 l/h - 8.0 l/h	6.0 l/h - 11.2 l/h - 16.0 l/h
Power supply	120 Vac 60 Hz	120 Vac 60 Hz
Fan total air flow-rate	360 mc/h	720 mc/h
Blower connection cable	AWG 14 with UA050%	AWG 14 with UA050%
	AWG 12 with UA090%	AWG 12 with UA090%
Maximum number of blower units (connected to one cabinet)	12	6

Tab. 14.k

Double blower units (for mounting in centre of corridor) UL version	DLA04UB*00	DLA08UB*00
Dimensions	640 x 200 x 400 mm	940 x 200 x 400 mm
Weight	9.2 kg	15.5 kg
Packaged dimensions	755 x 470 x 295 mm	1050 x 470 x 295 mm
Packaged weight	11.4 kg	18.0 kg
Delivery and storage temperature	-10/50°C 0-90%	-10/50°C 0-90%
Operating temperature	2/40°C 5-95%	2/40°C 5-95%
Ingress protection (IP)	IP10	IP10
Conformity	UL	UL
Water fitting	M16x1.5 Female	M16x1.5 Female
Water outlet	M16x1.5 Female	M16x1.5 Female
Number of nozzles	4	8
Flow-rate (depending on the type of nozzles)	6.0 l/h - 11.2 l/h - 16.0 l/h	12.0 l/h - 22.4 l/h - 32 l/h
Power supply	120 Vac 60 Hz	120 Vac 60 Hz
Fan total air flow-rate	720 m3/h	1,440 m3/h
Blower connection cable	AWG 14 with UA050%	AWG 14 with UA050%
	AWG 12 with UA090%	AWG 12 with UA090%
Maximum number of blower units (connected to one cabinet)	6	3

Tab. 14.l

**CAREL**

